



Virginia Aviation Board

May 2022

Board Package

**Virginia Aviation Board
Meeting Agenda
Wednesday, May 25, 2022**

The Virginia Aviation Board will hold a meeting at 1:00 p.m., Wednesday, May 25, 2022 at the Hotel 24 South, Shenandoah Ballroom, 24 South Market Street, Staunton, VA 24401.

- | | | |
|--|-----------------------------------|--------------|
| 1. Call to Order | Rod Hall, Chairman | (5 minutes) |
| 2. Review and approve February 3, 2022 minutes | Rod Hall, Chairman | (5 minutes) |
| 3. Virginia Aviation Board Resolutions and Recognitions | Rod Hall, Chairman | (10 minutes) |
| 4. DOAV Director's Update | Greg Campbell
Director
DOAV | (10 minutes) |
| 5. VABA Update | Bud Oakey,
President
VABA | (10 minutes) |
| 6. Old Business | | (5 minutes) |
| A. Airport Licensing Report | Vernon Carter | |
| 1. Lake Anna | DOAV | |
| 7. New Business | | |
| A. Bridge Loans | Susan Simmers
DOAV | (15 minutes) |
| B. Consideration of Amended FY22 Entitlement Utilization Plans | Mike Swain
DOAV | (10 minutes) |
| C. Virginia Aviation Board Review
Tentative Allocations from the Commonwealth Aviation Fund | Mike Swain
DOAV | (10 minutes) |
| 8. Public Comment Period
(3 minutes per person to address the board) | Rod Hall, Chairman | |
| 9. Board Member Comments and Reports | Rod Hall, Chairman | (5 minutes) |
| 10. Adjournment | | |



Virginia Aviation Board
Meeting Minutes

The Virginia Aviation Board held a meeting on Thursday, February 3, 2022, at the Virginia Department of Aviation Hangar Building, 5702 Gulfstream Road, Richmond, VA 23250. The meeting documents and presentation materials are available on the Virginia Department of Aviation's website, www.doav.virginia.gov.

MEMBERS

Roderick D. Hall, Chairman	Present
Sophie Chafin Vance, Region 1	Present
Victoria Cox, Region 2	Absent
Derek M. Hardwick, Region 3	Present
Alan C. Abbott, Region 4	Present
Maggie Ragon, Region 5	Present
Donald T. Robertson, Region 6	Present
Vanessa Christie, Region 7	Present

OTHER ATTENDEES

Christian Pedersen	Office of the Attorney General
P. Clifford Burnette, Acting Director	Virginia Department of Aviation

DOAV staff, state government representatives, federal government representatives, airport sponsors and managers, consultants, engineers, business owners, and city and county representatives were also present.

1. Call to Order Rod Hall, Chairman

Chairman Hall called the meeting to order at 11:04 a.m. and welcomed all in attendance. He noted that Mr. Greg Campbell was recently appointed as director of the Department of Aviation with his first day February 14, 2022. Mr. Burnette is serving as acting director.

2. Review and approve December 2, 2021 minutes Rod Hall, Chairman

Motion to approve: Hardwick

Second: Abbott

Vote: Aye: Vance, Hardwick, Abbott, Ragon, Robertson, Christie; Nay: none

3. Virginia Aviation Board Resolutions

Mr. Hardwick presented a framed Virginia Aviation Board Resolution to Dave Darrah in recognition of his services in the management of the Warrenton-Fauquier Airport.

Mr. Abbott read the Virginia Aviation Board Resolution for Hank Rempe recognizing his service to the Hanover County Municipal Airport. Mr. Abbott will make the official presentation to Mr. Rempe at the next Airport Commission meeting.

4. Mark Flynn Service Recognition Rod Hall, Chairman

Mr. Hall presented the framed state seal to Mark Flynn in recognition of his four years of service as director of the Virginia Department of Aviation and noted accomplishments made during his tenure.

5. DOAV Director's Update Cliff Burnette,
Acting Director, DOAV

Mr. Burnette provide an update on department news and activities including information on the Bipartisan Infrastructure Law (BIL) and Virginia Air Transportation Systems Plan.

6. VABA Update Bud Oakey, VABA

Mr. Oakey provided an update on VABA activities, noting highlights from the Aviation and Aerospace Legislative Reception held on February 2, 2022 and legislative interests.

7. Old Business

- A. Virginia Highlands Airport Bridge Loan Extension Request Mike Swain, DOAV

Mr. Swain discussed correspondence received from the Virginia Highlands Airport Authority. The sponsor requested that the first of five reimbursement installments against a bridge loan originally due to the department on December 31, 2021 be deferred to December 31, 2022. Staff recommended approval of the request.

Motion to approve: Vance

Second: Ragon

Vote: Aye: Vance, Hardwick, Abbott, Ragon, Robertson, Christie; Nay: none

- B. Airport Licensing Report Vernon Carter, DOAV

1. Lunenburg County Airport

Mr. Carter provided an update regarding the license for Lunenburg County Airport. He noted that the airport requested a Day/VFR license as they will not be able to complete the obstruction removal prior to expiration of the standard license. Staff recommended the issuance of the Day/VFR license to Lunenburg County Airport.

Motion to approve: Hardwick

Second: Vance

Vote: Aye: Vance, Hardwick, Abbott, Ragon, Robertson, Christie; Nay: none

2. Lake Anna Airport

Mr. Carter stated that the department had conducted an inspection in response to a pilot notification regarding potential obstructions on both ends of the runway. A conditional license was issued on January 11 and will expire on July 4. The department will provide an update to the board at the May meeting.

8. New Business

A. VRA Loan Application for Chesapeake Regional Airport Mike Swain, DOAV

Mr. Swain presented the Virginia Resources Authority (VRA) loan request for the Chesapeake Regional Airport in the amount of \$4.5 million for the Box H (2) Construction and FBO Building Construction project. Staff recommended endorsement of the VRA loan application.

Motion to approve: Robertson

Second: Vance

Vote: Aye: Vance, Hardwick, Abbott, Ragon, Robertson; Abstain: Christie; Nay: none

B. Consideration of Amended FY22 Entitlement Utilization Plans Mike Swain, DOAV

Mr. Swain presented revisions to FY22 Entitlement Utilization Plans for Newport News-Williamsburg International Airport, Norfolk International Airport, and Richmond International Airport. Staff recommended approval of the amended plans.

Motion to approve: Hardwick

Second: Abbott

Vote: Aye: Vance, Hardwick, Abbott, Ragon, Robertson, Christie; Nay: none

C. Virginia Aviation Allocations Review Mike Swain, DOAV
Tentative Allocations from the Commonwealth Aviation Fund

Mr. Swain presented the project requests and staff recommendations. The board actions are summarized below.

For Region 1, staff recommended the following:

Airport	Project Description	VAB Action	Amount
Blue Ridge Regional Airport	Land Acquisition Services Runway 13 RPZ/Part 77 BRIDGE LOAN - INCREASE	Approved	\$9,116.00
Lee County Airport	Fueling System Expansion - Jet A Tank (Construction)	Approved	\$65,878.00
New River Valley Airport	Hangar Site Preparation (Design)	Approved	\$45,062.00
Virginia Highlands Airport	Runway 6-24 Extension - Phase 4 (Construction)	Approved	\$444,444.00

Motion to approve: Vance

Second: Abbott

Vote: Aye: Vance, Hardwick, Abbott, Ragon, Robertson, Christie; Nay: none

For Region 2, staff recommended the following:

Airport	Project Description	VAB Action	Amount
Bridgewater Air Park	Runway/Taxiways Crackseal, Sealcoat, and Re-Marking (Construction)	Approved	\$136,000.00

Motion to approve: Abbott

Second: Christie

Vote: Aye: Vance, Hardwick, Abbott, Ragon, Robertson, Christie; Nay: none

For Region 3, staff recommended the following:

Airport	Project Description	VAB Action	Amount
Culpeper Regional Airport	Greenhouse Road Extension (Construction) (AIP)	Approved	\$257,777.00
	Greenhouse Road Extension (Construction) (non-AIP) *	Approved	\$557,097.00
Leesburg Executive Airport	North Apron Crack Seal & Seal Coat (Construction)	Approved	\$40,405.00
Manassas Regional Airport	Taxiway 'A' Pavement & Lighting Rehabilitation (Construction)	Approved	\$240,000.00
Winchester Regional Airport	Terminal Area Site Preparation - Phase 2 (Construction)	Approved	\$1,064,443.00
	Terminal Building (Design) - INCREASE	Approved	\$39,556.72
	Terminal Building Utilities (Construction)	Approved	\$98,580.00

For the Greenhouse Road Extension (Construction) (non-AIP) project, the VAB approved the project with the following contingency: It is anticipated that Bipartisan Infrastructure Law (BIL) funding will be treated as AIP Non-Primary Entitlement funds and as such, the funding may be used to reimburse prior project costs. The county is scheduled to receive \$296,000 in BIL funding each year for the next five years, and, if allowed by FAA/DOT, such funds shall be used to reimburse the Non-AIP Bridge Loan according to the standard procedures listed in the *Airport Program Manual*. If it is determined by the FAA that BIL funding cannot be used to reimburse prior construction costs, DOAV will amend the Non-AIP grant agreement to remove the Bridge Loan reimbursement requirement.

Motion to approve: Hardwick

Second: Vance

Vote: Aye: Vance, Hardwick, Abbott, Ragon, Robertson, Christie; Nay: none

For Region 4, staff recommended the following:

Airport	Project Description	VAB Action	Amount
Hanover County Municipal Airport	East Side Perimeter Fencing - Phase 2 (Construction)	Approved	\$52,380.00
Richmond Executive - Chesterfield County Airport	Airfield Drive Rehabilitation (Design) - INCREASE	Approved	\$25,200.00
	Southeast Box Hangars Site Preparation (Design) - CHANGE IN SCOPE	Disapproved	n/a

Motion to approve: Abbott

Second: Vance

Vote: Aye: Vance, Hardwick, Abbott, Ragon, Robertson, Christie; Nay: none

For Region 5, staff recommended the following:

Airport	Project Description	VAB Action	Amount
Allen C. Perkinson Municipal Airport	Apron Rehabilitation (Construction)	Approved	\$458,400.00
Danville Regional Airport	Access Control & Replacement Auto Gate (Construction)	Approved	\$31,129.00
	Airfield Directional Sign Replacement (Construction)	Approved	\$4,544.00

Fuel Farm Modification (Design)	Approved	\$36,660.00
South Ramp Rehabilitation - Phase 1 (Construction)	Approved	\$160,000.00
Terminal Building Renovation (Construction)	Approved	\$834,928.00
Terminal Building Replacement Furniture	Approved	\$42,434.00

Motion to approve: Ragon

Second: Christie

Vote: Aye: Vance, Hardwick, Abbott, Ragon, Robertson, Christie; Nay: none

For Region 6, staff recommended the following:

Airport	Project Description	VAB Action	Amount
Emporia-Greenville Regional Airport	Taxiway & Apron Rehabilitation - Phase 1 (Construction)	Approved	\$16,000.00
Lake Country Regional Airport	Runway Rehabilitation & RSA Improvement - Phase 4 (Construction)	Approved	\$1,236,000.00
Wakefield Municipal Airport	Runway Lighting Rehabilitation (Construction)	Approved	\$440,800.00

Motion to approve: Robertson

Second: Christie

Vote: Aye: Vance, Hardwick, Abbott, Ragon, Robertson, Christie; Nay: none

For Region 7, staff recommended the following:

Airport	Project Description	VAB Action	Amount
Accomack County Airport	Runway 21 Turnaround (Construction)	Approved	\$45,600.00
Chesapeake Regional Airport	AWOS Visibility Sensor Replacement	Approved	\$21,873.00
	Runway & Taxiway Lighting Rehabilitation (Construction)	Approved	\$100,000.00
Hampton Roads Executive Airport	Fueling System Expansion (Construction)	Approved	\$132,000.00
	West Apron Taxiways Rehabilitation - Phase 2 (Construction)	Approved	\$40,000.00
Suffolk Executive Airport	Terminal Apron Rehabilitation (Construction)	Approved	\$204,800.00
Williamsburg-Jamestown Airport	T-Hangar #2 Site Preparation (Construction)	Approved	\$516,000.00

Motion to approve: Christie

Second: Robertson

Vote: Aye: Vance, Hardwick, Abbott, Ragon, Robertson, Christie; Nay: none

9. Public Comment Period Rod Hall, Chairman

No public comments were offered.

10. Board Member Comments and Reports Rod Hall, Chairman

Region 1: Ms. Vance noted she was happy to be here. She encouraged a meeting in southwest Virginia.

Region 2: N/A

Region 3: Mr. Hardwick thanked Director Flynn and stated that he shared his interest in Advanced Air Mobility and hopes Mr. Greg Campbell shares this interest. He thanked Mr. Flynn for his illustrious service.

Region 4: Mr. Abbott echoed Mr. Hardwick's sentiments about Mr. Flynn.

Region 5: Ms. Ragon wished Mr. Flynn Godspeed and good fun.

Region 6: Mr. Robertson noted he was glad to be here and looks forward to meeting in southwest Virginia.

Region 7: Ms. Christie thanked all for their comments. She expressed appreciation to Mr. Flynn for his help and guidance. She congratulated Mr. Darrah and Mr. Rempe.

Chairman: Mr. Hall thanked the board members and Mr. Flynn for their service and assistance. He extended congratulations to Mr. Campbell and noted that he looks forward to productive relationships in advancing aviation through the Commonwealth.

Acting Director: Mr. Burnette announced his retirement effective February 24, 2022. He thanked the board and staff for their support during his 15 years as director of the Airport Services Division.

11. Adjournment

Rod Hall, Chairman

The meeting adjourned at 12:36 pm.

DRAFT

ENTITLEMENT UTILIZATION REPORTS & PLANS			
AMENDED FY2022 PLANS			
	FY2021 REPORT	FY2022 PLAN	
<u>AIRPORT</u>	<u>DOAV RECOMMENDATION</u>	<u>DOAV RECOMMENDATION</u>	<u>COMMENTS</u>
Charlottesville-Albemarle			
Eight new projects - \$1,480,504		Approve	
Newport News-Williamsburg Int'l			
Four new projects - \$640,000		Approve	
Richmond International			
One new project - \$50,467		Approve	
Shenandoah Valley Regional			
Four new projects - \$927,360		Approve	
		ACTION ITEM	

**Commonwealth Airport Fund
Entitlement Utilization Report and Plan**

Sponsor: **Charlottesville-Albemarle Airport Authority**

Airport: **Charlottesville Albemarle Airport**

Part 1 - Entitlement Utilization Report: FY2021

A. Entitlement Funds Available for Expenditure and Commitment

Total Funds Available for Commitment from FY2020	\$14,976,940.10
Entitlement Funds Received in FY2021	\$2,000,000.00
Interest Earned in FY2021	\$20,474.32
 Subtotal Entitlement Resources Available FY2021	 \$16,997,414.42

B. Reimbursement of State Entitlement Funds - PFC's; Bridge Loans; Other: FY2021

Project Description	AIP Project Number	DOAV Project Number	PFC Project Number	Funding Sources with Final Costs					Total Project Cost	State Funding Percentage	Reimbursement
				Federal	State Entitlement	State Discretionary	PFC	Local			

Subtotal Reimbursement of State Entitlement Funds \$0.00

Total Funds Available \$16,997,414.42 (Entitlement Resources Available FY2021 + Reimbursement of State Entitlement Funds)

C. Funding Expenditures for Projects Closed: FY2021

Project Description	AIP Project Number	DOAV Project Number	PFC Project Number	Funding Sources with Final Costs					Total Project Cost	State Funding Percentage	Estimated PFCs to Reimburse Entitlements
				Federal	State Entitlement	State Discretionary	PFC	Local			
RW 3-21 Overlay Construction	AIP46	N/A	N/A	10,573,184.58	\$1,174,798.29				\$ 11,747,982.87		\$ 1,174,798.29
Terminal & Landside Wayfinding & passenger amenities	N/A	N/A	19-24		\$103,102.34		25,775.59		\$ 128,877.93	80%	\$ 103,102.34
Green Initiative - Window energy tinting/modifications	N/A	N/A	N/A		\$120,608.76			\$30,152.19	\$ 150,760.95	80%	
MALSR Engineering Design and Repair Fees	N/A	N/A	19-24		\$321,373.10		80,343.29		\$ 401,716.39	80%	\$ 321,373.10
Remote Control Steep Slope Mower	N/A	N/A	N/A		\$91,723.20			\$22,930.80	\$ 114,654.00	80%	
Purchase 2 Airfield Ventrac Mowers	N/A	N/A	N/A		\$43,421.59			\$10,855.40	\$ 54,276.99	80%	
Bucket Truck	N/A	N/A	N/A		\$82,850.40			\$20,712.60	\$ 103,563.00	80%	
800 MHZ Radio System Emergency Response - equipment upgrade	N/A	N/A	N/A		\$130,542.89			\$32,635.72	\$ 163,178.61	80%	
FY21 Unanticipated eligible repair & maint (none this FY)	N/A	N/A	N/A		\$0.00			\$0.00	\$ -	0%	
FY21 Escalator Maint/repair	N/A	N/A	N/A		\$19,597.11			\$4,899.28	\$ 24,496.39	80%	
FY21 HVAC Maintenance & Repairs 78%	N/A	N/A	N/A		\$129,699.62			\$36,581.94	\$ 166,281.56	78%	
FY21 Elevator Maintenance & Repairs	N/A	N/A	N/A		\$22,656.17			\$5,664.04	\$ 28,320.21	80%	
FY21 Access Control Maintenance & Repairs	N/A	N/A	N/A		\$35,619.51			\$8,904.88	\$ 44,524.39	80%	
FY21 Rubber removal/ Ramp Joint Seal/Airfield Marking/pavement repair/ nav aid maint projects and airfield signage repair/replacement as identified by Part 139 inspection	N/A	N/A	N/A		\$150,224.15			\$37,556.04	\$ 187,780.19	80%	
FY21 KABA Exit Lane System and Automated Doors Maintenance & Repairs	N/A	N/A	N/A		\$4,165.76			\$1,041.44	\$ 5,207.20	80%	
FY21 ARFF/Tractors/Snow Removal Equipment - blades, wafer, tire replacement, etc.	N/A	N/A	N/A		\$65,615.98			\$16,403.99	\$ 82,019.97	80%	
FY21 Generator Maintenance & Repairs 78%	N/A	N/A	N/A		\$5,645.62			\$1,592.36	\$ 7,237.98	78%	
FY21 Plumbing System Repairs & Maintenance 78%	N/A	N/A	N/A		\$19,622.90			\$5,031.51	\$ 24,654.41	80%	
FY21 Fire Control System Maintenance & Repairs 78%	N/A	N/A	N/A		\$1,998.17			\$563.59	\$ 2,561.75	78%	
FY21 Jet bridge and Mobile Passenger Ramps Maintenance & Repairs	N/A	N/A	N/A		\$5,170.82			\$1,292.70	\$ 6,463.52	80%	
Terminal Technology upgrade (was on EUR20 as new FY21 Part 2 Proj Item 20)					\$35,129.38			\$8,782.35	\$ 43,911.73	80%	

Subtotal Expenditures for Projects Completed: FY2021 \$2,563,565.75 (State Entitlement Funds)

Unexpended Funds Available for Commitment \$14,433,848.67 (Total Funds Available - Expenditures for Completed Projects)

**Commonwealth Airport Fund
Entitlement Utilization Report and Plan**

D. Funding Commitments for Ongoing Projects

	Project Description	Estimated Fiscal Year of Completion	AIP Project Number	DOAV Project Number	PFC Project Number	Funding Sources with Estimated Costs					Estimated Total Project Cost	Estimated State Funding Percentage	Estimated PFCs to Reimburse Entitlements
						Federal	State Entitlement	State Discretionary	PFC	Local			
1	Terminal Expansion Project (project complete, need financial closeout)	2022	N/A	CS-45	CS-45		\$1,172,205.00	\$2,697,582.00	\$73,504.00	\$380,493.00	\$4,323,784.00	89.5%	\$1,172,205.00
2	Terminal Expansion Project costs overrun awaiting approval	2022	N/A	CS-45	CS-45		\$652,112.00			\$76,505.00	\$728,617.00	89.5%	\$652,112.00
3	AIP Air Carrier Ramp - North & Ramp Lighting Upgrade Construction (and ALP Update)	2022	48	N/A	19-24	\$3,690,181.00	\$410,020.00			\$0.00	\$4,100,201.00	10.0%	\$410,020.00
4	Non-AIP Air Carrier Ramp - North & Ramp Light Upgrade Const	2022	N/A	N/A	19-24		\$3,806,383.00			\$951,596.00	\$4,757,979.00	80.0%	\$3,806,383.00
5	Escalators Replacement at Gate 5	2023	N/A	N/A	18-23		\$800,000.00			\$200,000.00	\$1,000,000.00	80.0%	\$800,000.00
6	Gutter Replacement ARFF building	2022	N/A	N/A	N/A		\$12,800.00			\$3,200.00	\$16,000.00	80.0%	
7	Escalators Replacement at Gate 1A	2023	N/A	N/A	18-23		\$800,000.00			\$200,000.00	\$1,000,000.00	80.0%	\$800,000.00
8	Security System Update Phase 2	2022	N/A	N/A	Future		\$80,000.00			\$20,000.00	\$100,000.00	80.0%	\$80,000.00
9	Air Carrier Ramp Passenger Walkways (AIP)	2023	Future	N/A	19-24	\$1,980,000.00	\$220,000.00				\$2,200,000.00	10.0%	\$220,000.00
9A	Air Carrier Ramp Passenger Walkways (Non-AIP)	2023	N/A	N/A	19-24		\$400,000.00			\$100,000.00	\$500,000.00	80.0%	\$400,000.00
10	Emergency Generator Phase 1	2022	N/A	N/A	Future		\$480,000.00			\$120,000.00	\$600,000.00	80.0%	\$480,000.00
11	Terminal Technology (PY 2 line items)	2022	N/A	N/A	N/A		\$152,000.00			\$38,000.00	\$190,000.00	80.0%	
12	GA Ramp Improvements	2023	N/A	N/A	N/A		\$800,000.00			\$200,000.00	\$1,000,000.00	80.0%	
13	Inbound Bag Belt Replacement (Baggage Claim)	2022	N/A	N/A	18-23		\$400,000.00			\$100,000.00	\$500,000.00	80.0%	\$400,000.00
14	Upgrade Lighting	2022	N/A	N/A	N/A		\$7,800.00			\$1,950.00	\$9,750.00	80.0%	
15	Radio update - CHO's portion of Region-wide project	2023	N/A	N/A	N/A		\$276,480.00		\$69,120.00		\$345,600.00	80.0%	
16	Terminal Modification Gate 5/Bag Claim Design - Terminal expansion design	2022	N/A	N/A	Future		\$780,000.00		\$220,000.00		\$1,000,000.00	78.0%	\$780,000.00
17	Big Fans for terminal concourse	2022	N/A	N/A	N/A		\$72,000.00			\$18,000.00	\$90,000.00	80.0%	
18	Entrance Door Replacements (3 sets)	2022	N/A	N/A	18-23		\$120,000.00		\$30,000.00		\$150,000.00	80.0%	\$120,000.00
19	Air Carrier Ramp Remarking Project (Design/ Eradication/Re-marking/Inspections)	2022	N/A	N/A	N/A		\$160,000.00			\$40,000.00	\$200,000.00	80.0%	
20	Fence Improvements	2022	N/A	N/A	N/A		\$32,000.00			\$8,000.00	\$40,000.00	80.0%	
21	Obstruction Removal as identified by FAA	2022	N/A	N/A	N/A		\$24,000.00			\$6,000.00	\$30,000.00	80.0%	
22	Snow Removal Equipment Storage Shop Improvements	2022	N/A	N/A	N/A		\$240,000.00			\$60,000.00	\$300,000.00	80.0%	
23	Rehab Public Elevator at Gate 5	2023	N/A	N/A	N/A		\$200,000.00			\$5,000.00	\$205,000.00	80.0%	
24	Out Bound Baggage Belt	2022	N/A	N/A	18-23		\$160,000.00		\$40,000.00		\$200,000.00	80.0%	\$160,000.00
25	Repayment of 3 VDOA Bridge Loans (Lad, EA, Obstructions)	2022	Future	N/A	18-23	\$369,097.00	\$259,819.00	\$41,011.00	\$64,955.00		\$734,882.00	35.4%	\$259,819.00
26	Terminal Technology to inc IT room modification	2022	N/A	N/A	Future		\$160,000.00			\$40,000.00	\$200,000.00	80.0%	\$160,000.00
27	Paint Interior of Terminal	2022	N/A	N/A	N/A		\$80,000.00			\$20,000.00	\$100,000.00	80.0%	
28	Clean and recaulk exterior of terminal	2022	N/A	N/A	N/A		\$78,000.00			\$22,000.00	\$100,000.00	78.0%	
29	Airfield Pre&Post Emergent Application	2022	N/A	N/A	N/A		\$32,000.00			\$8,000.00	\$40,000.00	80.0%	
30	Paint Exterior of ARFF Building	2022	N/A	N/A	N/A		\$32,000.00			\$8,000.00	\$40,000.00	80.0%	
31	Terminal Gutter Installation	2022	N/A	N/A	N/A		\$39,000.00			\$11,000.00	\$50,000.00	78.0%	
32	Airport-Wide Security Upgrade requires letter from TSA 1542	2022	Future	N/A	Future	\$720,000.00	\$80,000.00				\$800,000.00	10.0%	\$80,000.00
33	SRE Storage Structure	2022	N/A	N/A	N/A		\$120,000.00			\$30,000.00	\$150,000.00	80.0%	
34	Land Acquisition for Runway Protection	2022	N/A	N/A	Future		\$720,000.00			\$180,000.00	\$900,000.00	80.0%	\$720,000.00
35	Mechanic Equipment Lift	2022	N/A	N/A	N/A		\$40,000.00			\$10,000.00	\$50,000.00	80.0%	
36	Replace ARFF Roof	2022	N/A	N/A	Future		\$160,000.00			\$40,000.00	\$200,000.00	80.0%	\$160,000.00
37	ARFF Building Rehab Phase 1	2022	N/A	N/A	Future		\$160,000.00			\$40,000.00	\$200,000.00	80.0%	\$160,000.00
38	Terminal Ceiling Tile Replacement - material only / labor provided in-house	2022	N/A	N/A	N/A		\$25,000.00			\$0.00	\$25,000.00	100.0%	
39	ARFF Building Phase 2- Rehab/Mitigation	2022	N/A	N/A	Future		\$160,000.00			\$40,000.00	\$200,000.00	80.0%	\$160,000.00
40	Install Guard Rail Along Bowen Loop near Basin	2022	N/A	N/A	N/A		\$20,000.00			\$5,000.00	\$25,000.00	80.0%	
41	Recondition Terrazzo	2022	N/A	N/A	N/A		\$120,000.00			\$30,000.00	\$150,000.00	80.0%	
42	Replace 1990 Airfield Bush hog & Tractor	2022	N/A	N/A	N/A		\$104,000.00			\$26,000.00	\$130,000.00	80.0%	
43	Terminal Technology	2022	N/A	N/A	N/A		\$40,000.00			\$10,000.00	\$50,000.00	80.0%	
44	Rehab Bricks and Concrete on Curbside	2022	N/A	N/A	N/A		\$80,000.00			\$20,000.00	\$100,000.00	80.0%	
45	Asphalt Crack Seal Equipment	2022	N/A	N/A	N/A		\$68,000.00			\$17,000.00	\$85,000.00	80.0%	
46	SRE Mechanical Equipment Lift	2022	N/A	N/A	N/A		\$40,000.00			\$10,000.00	\$50,000.00	80.0%	
47	Terminal Area Plan (for expense incurred after approval date of EUR)	2022	N/A	N/A	19-24		\$350,000.00	\$350,000.00			\$700,000.00	50.0%	\$350,000.00
48	Modular Gate Area	2022	N/A	N/A	N/A		\$160,000.00			\$40,000.00	\$200,000.00	80.0%	
49	Purchase Box Blade for 2021 Tractor	2022	N/A	N/A	N/A		\$12,000.00			\$3,000.00	\$15,000.00	80.0%	
50	Airfield lighting conversion to LED/signs/vault update -Const Phase 1	2022	Future	N/A	Future	\$675,000.00	\$75,000.00				\$750,000.00	10.0%	\$75,000.00
51	FY22 Unanticipated eligible repair & maint	2022	N/A	N/A	N/A		\$80,000.00			\$20,000.00	\$100,000.00	80.0%	
52	FY 22 Escalator Maint/repair	2022	N/A	N/A	N/A		\$40,000.00			\$10,000.00	\$50,000.00	80.0%	
53	FY 22 HVAC Maint/repair - VDOA 78% funding	2022	N/A	N/A	N/A		\$117,000.00			\$33,000.00	\$150,000.00	78.0%	
54	FY22 Elevator Maint/repair	2022	N/A	N/A	N/A		\$40,000.00			\$10,000.00	\$50,000.00	80.0%	
55	FY22 Access Control Maint/repair	2022	N/A	N/A	N/A		\$32,000.00			\$8,000.00	\$40,000.00	80.0%	

VAB Package May 2022

**Commonwealth Airport Fund
Entitlement Utilization Report and Plan**

56	FY 22 Rubber removal/ Ramp Joint Seal/Airfield Marking/pavement repair Projects. Also maint/repairs of airfield Equipment/Systems Maintenance Required for Part 139 Certification	2022	N/A	N/A	N/A		\$240,000.00			\$60,000.00	\$300,000.00	80.0%	
57	FY21 KABA Maint/repair	2022	N/A	N/A	N/A		\$60,000.00			\$15,000.00	\$75,000.00	80.0%	
58	FY22 ARFF/Tractors/Snow Removal Equipment - blades, wafer, tire replacement, etc.	2022	N/A	N/A	N/A		\$64,000.00			\$16,000.00	\$80,000.00	80.0%	
59	FY22 Generator Maint and Repair -VDOA 78% funding	2022	N/A	N/A	N/A		\$19,500.00			\$5,500.00	\$25,000.00	78.0%	
60	FY22 Fire Control System Main - VDOA 78% funding	2022	N/A	N/A	N/A		\$19,500.00			\$5,500.00	\$25,000.00	78.0%	
61	FY22 Jet bridge and Mobile Passenger Ramps Maint/Repair	2022	N/A	N/A	N/A		\$32,000.00			\$8,000.00	\$40,000.00	80.0%	
62	FY22 Plumbing Repairs - VDOA 78% funding	2022	N/A	N/A	N/A		\$31,200.00			\$8,800.00	\$40,000.00	78.0%	
63	FY22 FIDS & PA Repairs and Maint.	2022	N/A	N/A	N/A		\$40,000.00			\$10,000.00	\$50,000.00	80.0%	
64	Energy Modification pre-screening	2022	N/A	N/A	N/A		\$120,000.00			\$30,000.00	\$150,000.00	80.0%	
65	Gate 5 Ramp Entrance Modification	2022	N/A	N/A	Future		\$400,000.00			\$100,000.00	\$500,000.00	80.0%	\$400,000.00
66	Air Carrier Ramp - Fire Extinguisher Purchase	2022	N/A	N/A	N/A		\$16,000.00			\$4,000.00	\$20,000.00	80.0%	
67	Terminal Technology	2022	N/A	N/A	N/A		\$32,000.00			\$8,000.00	\$40,000.00	80.0%	

Subtotal Funding Commitments for Ongoing Projects	\$16,675,819.00	(State Entitlement Funds)
Anticipated FY2022 Entitlement Funds (use last year's amount)	\$2,000,000.00	
Funds Available	-\$241,970.33	(Unexpended Funds Available for Commitment - Funding Commitments for Ongoing Projects + Anticipated FY2022 Entitlement Funds)

Part 2 - Entitlement Utilization Plan: FY2022

A. Project Listing

EUP #	Project Description	6-Year Plan Y / N	Estimated Start Date (Fiscal Year)	AIP Project Number	DOAV Project Number	PFC Project Number	Funding Sources with Estimated Costs					Estimated Total Project Cost	Estimated State Funding Percentage	Estimated PFCs to Reimburse Entitlements
							Federal	State Entitlement	State Discretionary	PFC	Local			
1	Modular Gate Area (increased costs to project #48- above)	Y	2022	N/A	N/A	N/A		\$160,000.00			\$40,000.00	\$ 200,000.00	80.0%	
2	Airfield Equipment-Snow Blower	Y	2022	Future	N/A	N/A	\$644,040.00	\$71,560.00			\$43,400.00	\$ 759,000.00	9.4%	
3	Air Carrier Ramp Upgrade	Y	2022	Future	N/A	N/A	\$900,000.00	\$100,000.00				\$ 1,000,000.00	10.0%	
4	Terminal Aged Infrastructure Renovations and Improvements	Y	2022	Future	N/A	N/A	\$13,252,500.00	\$672,500.00	\$25,000.00			\$ 13,950,000.00	4.8%	
5	FY22 800 MHz Radio System Emergency Response equip maint	Y	2022	N/A	N/A	N/A		\$16,000.00		\$4,000.00		\$ 20,000.00	80%	
6	Terminal PA speakers and equipment upgrade	Y	2022	N/A	N/A	N/A		\$80,000.00		\$20,000.00		\$ 100,000.00	80%	
7	Safety Equipment for FY21 ARFF Vehicle	Y	2022	N/A	N/A	N/A		\$70,771.00		\$17,693.00		\$ 88,464.00	80%	
8	Airfield Lighting Conversion to LED/Vault/Signs (increased Cost to project #50 above)	Y	2022	Future	N/A	N/A	\$ 2,787,052.00	\$309,673.00				\$ 3,096,725.00	10%	

Total Planned Commitments for Future Projects	\$1,480,504.00	(State Entitlement Funds)
Funds Available	-\$1,722,474.33	

B. Project Narratives

EUP #	Narrative
1	This project was previously submitted and approved. Once the building arrived, it was determined that the work to install and make the building usable was more than anticipated. Explanation provided and increase approved by Mike Swain. Email 3/10/22
2	Airfield Equipment-Snow Blower - This project will fund the replacement of the Airport's older snow blower which is reaching the end of its useful life.
3	Air Carrier Ramp Upgrade - This project will fund an upgrade to the Airport's original air carrier ramp. Portions of this section of ramp are over 37-years old
4	Terminal Aged Infrastructure Renovations and Improvements - As provided in the Bipartisan infrastructure Bill, CHO submitted an application for this year's competitive FAA grant process. We do not know if we will be successful in getting any portion of this year's grant funding, but several individual projects which will improve the terminal aging infrastructure, sustainability projects, and ADA projects were submitted
5	FY22 800 MHz Radio System Emergency Response equip maint - A third-party provider maintains the Airport's emergency response radio system. This project will fund the expenses associated with maintaining the system

**Commonwealth Airport Fund
Entitlement Utilization Report and Plan**

6	Terminal PA speakers and equipment upgrade -This project will upgrade PA speakers and other PA equipment throughout the public portion of the terminal
7	Safety Equipment for FY21 ARFF Vehicle - This project will fund additional safety equipment for the FY21 RosenBauer ARFF Vehicle and other ARFF equipment
8	Airfield Lighting Conversion to LED/Vault/Signs (increased Cost to project #50 above) The project bids have been received and this project will fund the variance between what was previously included in the EUR and the actual project costs

Part 3 - I As the Executive Director on behalf of the sponsor, I certify that the information provided above is accurate and complete to the best of my knowledge.

Melinda C Crawford
Signature
Melinda C. Crawford
Printed Name
5/10/2022
Date

As the Chief Financial Officer on behalf of the sponsor, I certify that the information provided above is accurate and complete to the best of my knowledge.

Penny Shifflett
Signature
Penny Shifflett
Printed Name
5/10/2022
Date

CHO – 2022 EUR Revised 4/25/2022

Part 2 – Entitlement Utilization Plan: FY2022

Project Narratives – Sketches

1.	Modular Gate Area (increased costs to project #48- above)
----	---



In May 2021, this project was added to the EUR. The actual cost to purchase the building and to install the ADA ramps and building connections was \$200,000 more than anticipated. This project will fund the remaining expenses.

CHO – 2022 EUR Revised 4/25/2022

Part 2 – Entitlement Utilization Plan: FY2022

Project Narratives – Sketches

2	Airfield Equipment – Snow Blower Equipment
---	--



This project will fund the match for the FAA grant to purchase an OshKosh Snow Blower.

CHO – 2022 EUR Revised 4/25/2022

Part 2 – Entitlement Utilization Plan: FY2022

Project Narratives – Sketches

3

Air Carrier Ramp Upgrade

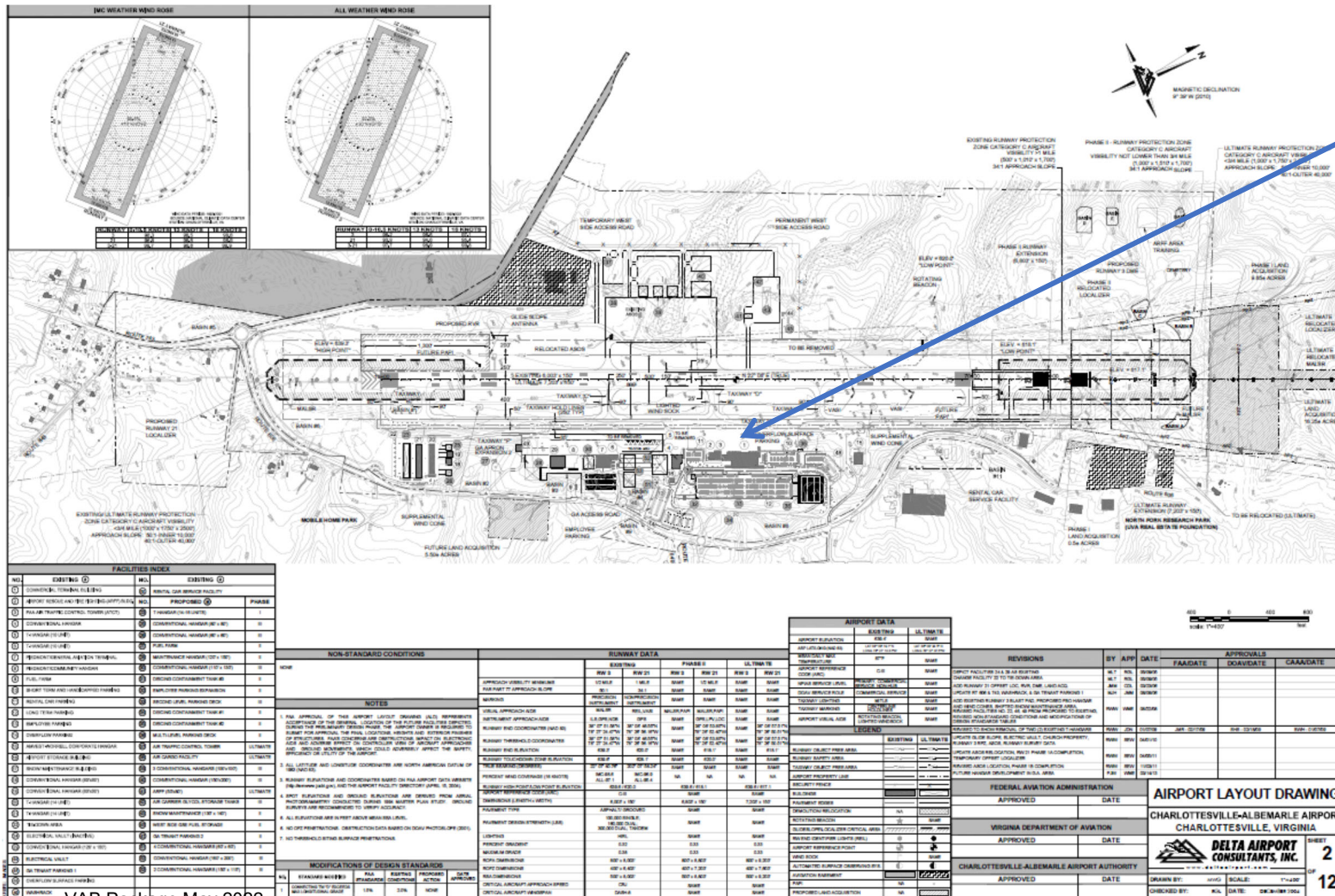

This project will fund an upgrade to portions of the the Airport's original air carrier ramp.

CHO – 2022 EUR Revised 4/25/2022

Part 2 – Entitlement Utilization Plan: FY2022

Project Narratives – Sketches

4 Terminal Aged Infrastructure Renovations and Improvements -

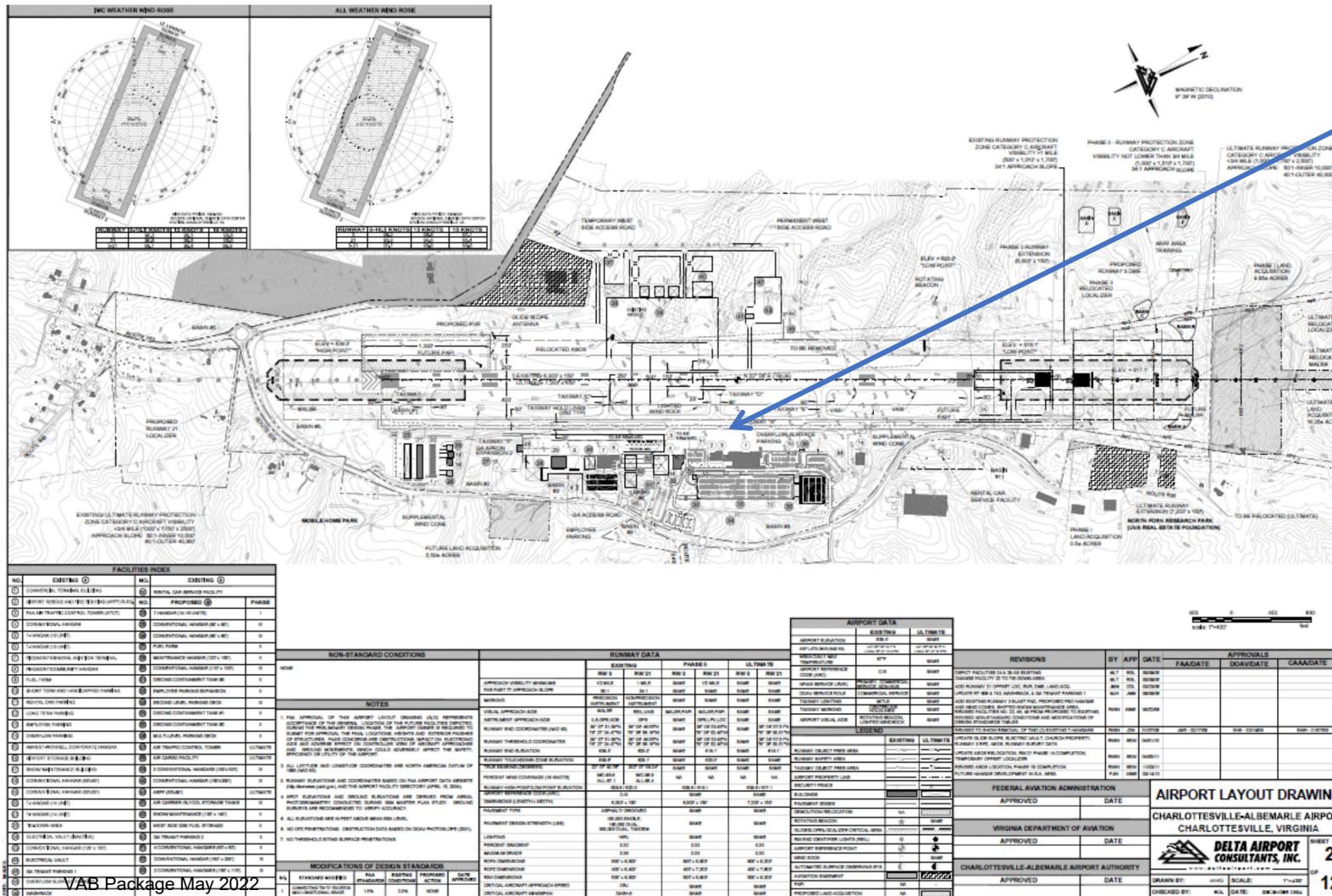

Several individual projects that will improve the terminal aging infrastructure, sustainability projects, and ADA projects were submitted in this FAA grant application



CHO – 2022 EUR Revised 4/25/2022

Part 2 – Entitlement Utilization Plan: FY2022

Project Narratives – Sketches

8. Airfield lighting conversion to LED/signs/vault update -Const

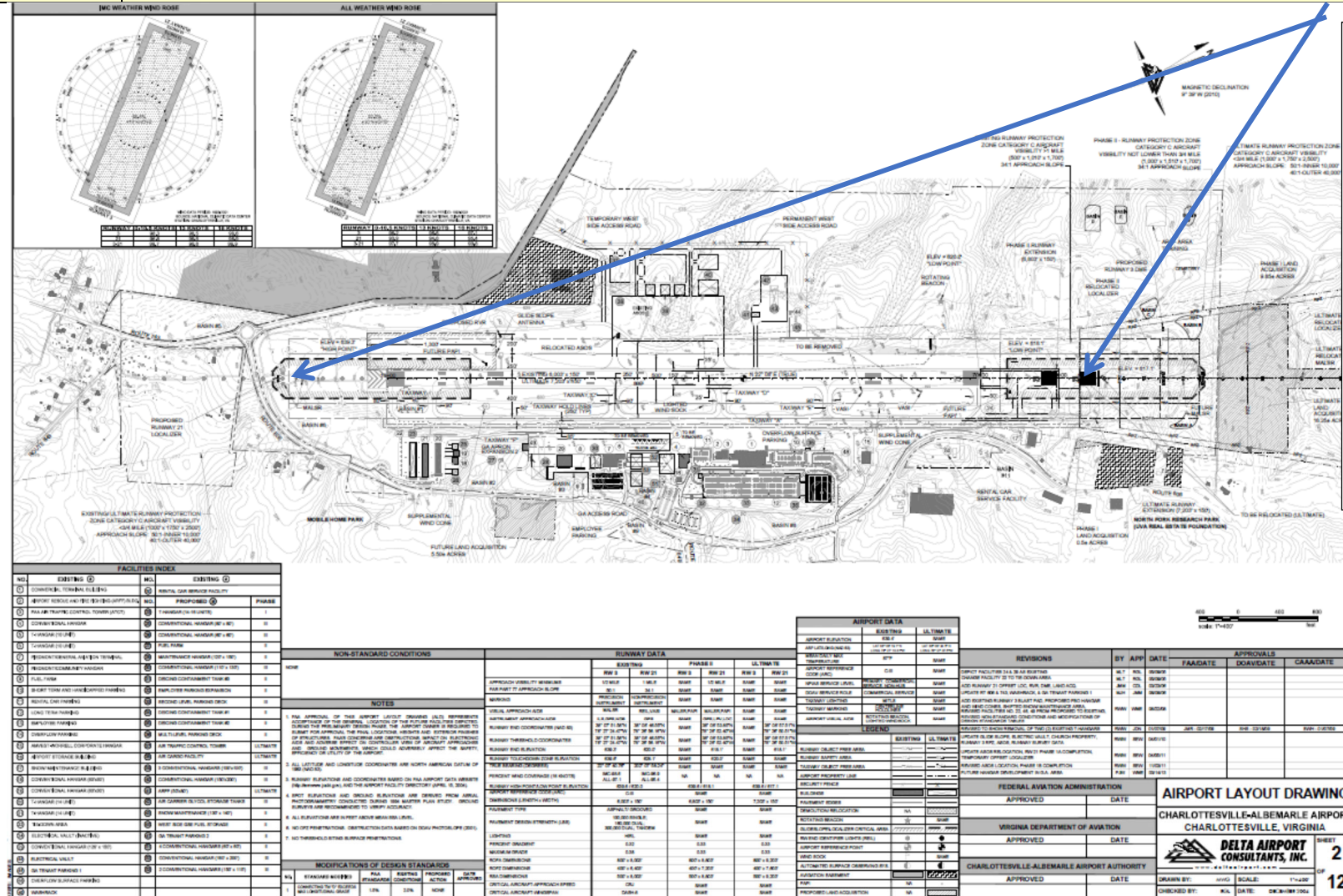

This project will upgrade all runway/taxiway lighting and signage. The electrical airfield vault will also be updated.

The project bids have been received and this project will fund the variance between what was previously included in the EUR and the actual project costs

Commonwealth Airport Fund Entitlement Utilization Report and Plan

Sponsor: Peninsula Airport Commission

Airport: Newport News/Williamsburg International Airport

Entitlement Funds Available for Expenditure and Commitment

Total Funds Available for Commitment from FY2020	\$8,342,474.54
Entitlement Funds Received in FY2021	\$2,000,000.00
Interest Earned in FY2021	\$40,043.88
 Subtotal Entitlement Resources Available FY2021	 \$10,382,518.42

Reimbursement of State Entitlement Funds - PFC's; Bridge Loans; Other: FY2021

Project Description	AIP Project Number	DOAV Project Number	PFC Project Number	Funding Sources with Final Costs					Total Project Cost	State Funding Percentage	Reimbursement
				Federal	State Entitlement	State Discretionary	PFC	Local			
None									\$ -		

Subtotal Reimbursement of State Entitlement Funds \$0.00

Total Funds Available \$10,382,518.42 (Entitlement Resources Available FY2021 + Reimbursement of State Entitlement Funds)

Funding Expenditures for Projects Closed: FY2021

Project Description	AIP Project Number	DOAV Project Number	PFC Project Number	Funding Sources with Final Costs					Total Project Cost	State Funding Percentage	Estimated PFCs to Reimburse Entitlements
				Federal	State Entitlement	State Discretionary	PFC	Local			
Portable 6 inch trash/water pump					\$15,180.00			\$3,795.00	\$ 18,975.00	80%	
AHU #1 Dampers 4 Each					\$10,314.40			\$15,471.60	\$ 25,786.00	40%	
AHU #2 Dampers 4 Each					\$6,079.60			\$9,119.40	\$ 15,199.00	40%	
Zero turn mower					\$8,447.21			\$2,111.80	\$ 10,559.01	80%	
ARFF #1 Rescue tires					\$8,455.17			\$2,113.79	\$ 10,568.96	80%	
ARFF #3 Rescue tires					\$8,491.04			\$2,122.76	\$ 10,613.80	80%	
JLG or similar lift					\$44,184.00			\$11,046.00	\$ 55,230.00	80%	
Bond Debt South Corporate					\$155,000.00			\$0.00	\$ 155,000.00	100%	
Escalator and Elevator Inspection and Maintenance					\$5,963.58			\$1,490.89	\$ 7,454.47	80%	
Repair Security fence Oriana Rd					\$1,080.00			\$270.00	\$ 1,350.00	80%	
Replace U joint shaft and shield (In House repair)					\$1,471.80			\$0.00	\$ 1,471.80	100%	
Replace Taxiway CCR PCB and Cut out (In House repair)					\$1,226.52			\$0.00	\$ 1,226.52	100%	
Replace two in-line boiler pump motors					\$2,760.00			\$4,140.00	\$ 6,900.00	40%	
Replace bumper turret control box on ARFF truck (In House repair)					\$14,639.69			\$0.00	\$ 14,639.69	100%	
Site visit repair FIDS					\$2,648.00			\$662.00	\$ 3,310.00	80%	
Repair fire alarm deficiencies terminal wide					\$2,029.30			\$3,043.95	\$ 5,073.25	40%	
Load bank airfield vault generator					\$1,920.96			\$480.24	\$ 2,401.20	80%	
Repair leaks in terminal air chiller #2					\$4,330.52			\$6,495.78	\$ 10,826.30	40%	
Replace ARFF truck thermal camera kit (In House repair)					\$22,072.43			\$0.00	\$ 22,072.43	100%	
Perimeter Road Approach End Runway 2 and 7 Construction	3-51-0035-051-2019				\$2,834,100.00	\$314,900.00		\$0.00	\$ 3,149,000.00	10%	
Security Camera Upgrades Phase 2					\$42,621.86			\$10,655.47	\$ 53,277.33	80%	
PA System Replacement					\$44,414.00			\$66,620.00	\$ 111,034.00	40%	
Backhoe					\$72,560.00			\$18,140.00	\$ 90,700.00	80%	
Firehouse Generator					\$32,521.86			\$8,130.46	\$40,652.32	80%	
10K Loader					\$136,800.00			\$34,200.00	\$ 171,000.00	80%	
Airfield Lighting, Globes, Gaskets, Signage Panels, Windsocks					\$13,183.55			\$3,295.89	\$ 16,479.44	80%	
Airfield paint removal, painting and crack sealing					\$36,092.00			\$7,862.00	\$ 43,954.00	82%	
Annual and Quarterly VAB Package May 2022					\$1,616.00			\$2,424.00	\$ 4,040.00	40%	

**Commonwealth Airport Fund
Entitlement Utilization Report and Plan**

Annual Maintenance and Inspection of Boilers/Chillers/Cooling Towers					\$4,356.00			\$6,534.00	\$ 10,890.00	40%	
Design Taxiway A Lighting, Shoulders & Realignment Txys B & C	3-51-0035-052-2019			\$ 302,400.00	\$33,600.00				\$ 336,000.00	10%	

Subtotal Expenditures for Projects Completed: FY2021 \$1,026,887.06 (State Entitlement Funds)

Unexpended Funds Available for Commitment \$9,355,631.36 (Total Funds Available - Expenditures for Completed Projects)

Commonwealth Airport Fund Entitlement Utilization Report and Plan

Funding Commitments for Ongoing Projects

Project Description	Estimated Fiscal Year of Completion	AIP Project Number	DOAV Project Number	PFC Project Number	Funding Sources with Estimated Costs					Estimated Total Project Cost	Estimated State Funding Percentage	Estimated PFCs to Reimburse Entitlements
					Federal	State Entitlement	State Discretionary	PFC	Local			
Construction Txy A Lighting, Shoulders & Realignment of Txys B & C	2022				\$5,320,777.00					\$ 5,320,777.00	0%	
Terminal building fire alarm sprinkler pump repair	2022					\$1,839.20			\$2,758.80	\$ 4,598.00	40%	
Airfield Lighting, Globes, Gaskets, Signage Panels, Windsocks	2022					\$16,000.00			\$4,000.00	\$ 20,000.00	80%	
Repair expansion joints ARRF Station	2022					\$24,000.00			\$6,000.00	\$ 30,000.00	80%	
GA Ramp Rehab Environmental and Design	2022			6.2		\$160,000.00		\$40,000.00		\$ 200,000.00	80%	
Purchase 22ft Winged Cutter	2022					\$56,000.00			\$14,000.00	\$ 70,000.00	80%	
Access Control System	2022					\$80,000.00			\$120,000.00	\$ 200,000.00	40%	
South Corp Apron Rehabilitation Design and Bidding	2022			6.1		\$180,000.00		\$45,000.00		\$ 225,000.00	80%	
South Corporate Development - Environmental Analysis	2022			6.1		\$200,000.00		\$50,000.00		\$ 250,000.00	80%	
South Corporate Development - Permitting and Mitigation	2022			6.1		\$120,000.00		\$30,000.00		\$ 150,000.00	80%	
South Corporate Pavement Analysis	2022			6.1		\$48,000.00		\$12,000.00		\$ 60,000.00	80%	
Escalator and Elevator Inspection and Maintenance	2022					\$8,400.00			\$2,100.00	\$ 10,500.00	80%	
Firehouse Roof Repair Phase 2	2022					\$32,000.00			\$8,000.00	\$ 40,000.00	80%	
Design Baggage Claim Rehabilitation	2022			6.3		\$240,000.00		\$60,000.00		\$ 300,000.00	80%	
Drainage Repair G Avenue	2022					\$11,000.00				\$ 11,000.00	100%	
Obstruction Survey	2022					\$80,000.00			\$20,000.00	\$ 100,000.00	80%	
FOD Boss	2022					\$8,000.00			\$2,000.00	\$ 10,000.00	80%	
Replacement Incoming Bag Belt Systems Phase 1	2023			6.3		\$720,000.00		\$180,000.00		\$ 900,000.00	80%	
Replacement Incoming Bag Belt Systems Phase 2	2024			6.3		\$720,000.00		\$180,000.00		\$ 900,000.00	80%	
Terminal Window Replacement Phase 2	2022			6.5		\$40,000.00		\$60,000.00	\$0.00	\$ 100,000.00	40%	
Dump Truck with plow	2022					\$120,000.00			\$30,000.00	\$ 150,000.00	80%	
Main Terminal Building Rehabilitation Design	2022			6.5		\$240,000.00		\$60,000.00		\$ 300,000.00	80%	
Main Terminal Roof Repair Phase 2 Brick Infiltration Mitigation	2022					\$400,000.00			\$600,000.00	\$ 1,000,000.00	40%	
Old Terminal Design & Environmental Phase 1	2022					\$480,000.00			\$120,000.00	\$ 600,000.00	80%	
Main Terminal Roof Repair Phase 1	2022					\$30,000.00			\$45,000.00	\$ 75,000.00	40%	
Flight Information Display System	2022					\$40,000.00			\$10,000.00	\$ 50,000.00	80%	
SRE Facility	2024					\$2,400,000.00			\$600,000.00	\$ 3,000,000.00	80%	
Wayfinding Study Phase 1	2022					\$20,000.00			\$30,000.00	\$ 50,000.00	40%	
Relocate /Combine Upper & Lower Level Fire Panels circuits to main fire panel on main level	2022					\$12,000.00			\$18,000.00	\$ 30,000.00	40%	
Bond Debt South Corporate	2022					\$155,000.00				\$ 155,000.00	100%	
Bond Debt South Corporate	2023					\$155,000.00				\$ 155,000.00	100%	
Bond Debt South Corporate	2024					\$155,000.00				\$ 155,000.00	100%	
Security Cameras Phase 3	2022					\$200,000.00			\$50,000.00	\$ 250,000.00	80%	
MDP Over/Under voltage protection main power to terminal	2021					\$12,000.00			\$8,000.00	\$ 20,000.00	60%	
Facility Infrastructure and Equipment Repairs and Maintenance	2022					\$160,000.00			\$40,000.00	\$ 200,000.00	80%	
SRE Facility Design Siting & Environmental	2023					\$400,000.00			\$100,000.00	\$ 500,000.00	80%	
Airfield paint removal, painting and crack sealing	2022					\$160,000.00			\$40,000.00	\$ 200,000.00	80%	
Annual and Quarterly Fire Sprinkler and Suppression Inspections	2022					\$2,024.00			\$3,036.00	\$ 5,060.00	40%	
Annual Maintenance and Inspection of Boilers/Chillers/Cooling Towers	2022					\$4,877.00			\$7,315.00	\$ 12,192.00	40%	
Integrate mass notification system airport wide	2022					\$24,000.00			\$6,000.00	\$ 30,000.00	80%	
Annual maintenance and inspection AFFF system water and foam ratio on fire trucks	2022					\$9,600.00			\$2,400.00	\$ 12,000.00	80%	
Install supplemental air conditioning in main communications room	2022					\$8,000.00			\$12,000.00	\$ 20,000.00	40%	
Airfield lighting controls system upgrade	2022					\$24,000.00			\$6,000.00	\$ 30,000.00	80%	
Sweeper	2022					\$100,000.00			\$25,000.00	\$ 125,000.00	80%	
Fuel farm upgrade	2022					\$ 33,300.00			\$66,700.00	\$ 100,000.00	33%	
Master Plan Update	2022				\$900,000.00	\$ 100,000.00				\$ 1,000,000.00	10%	
Utility Vehicle	2022					\$ 24,000.00			\$6,000.00	\$ 30,000.00	80%	
Renovate Entire Baggage Claim System	2022					\$ 200,000.00			\$50,000.00	\$ 250,000.00	80%	
Repair/Replace Fiber Optics Cable, Airfield Lighting System	2022					\$ 72,000.00			\$18,000.00	\$ 90,000.00	80%	

**Commonwealth Airport Fund
Entitlement Utilization Report and Plan**

Old Terminal Abatement Lead Paint/Asbestos Phase II	2022				\$ 960,000.00			\$240,000.00	\$ 1,200,000.00	80%	
Old Terminal Demo Phase 3 and Phase 4	2022				\$ 800,000.00			\$200,000.00	\$ 1,000,000.00	80%	
Subtotal Funding Commitments for Ongoing Projects		\$10,246,040.20	(State Entitlement Funds)								
					\$6,220,777.00	\$10,246,040.20	\$0.00	\$717,000.00	\$2,512,309.80	\$19,696,127.00	
Anticipated FY2022 Entitlement Funds (use last year's amount)		\$2,000,000.00									

Commonwealth Airport Fund Entitlement Utilization Report and Plan

Funds Available \$1,109,591.16 (Unexpended Funds Available for Commitment - Funding Commitments for Ongoing Projects + Anticipated FY2022 Entitlement Funds))

Project Listing

EUP #	Project Description	6-Year Plan Y / N	Estimated Start Date (Fiscal Year)	AIP Project Number	DOAV Project Number	PFC Project Number	Funding Sources with Estimated Costs					Estimated Total Project Cost	Estimated State Funding Percentage	Estimated PFCs to Reimburse Entitlements
							Federal	State Entitlement	State Discretionary	PFC	Local			
1	Airfield Lighting, Globes, Gaskets, Signage Panels, Windssocks							\$16,000.00			\$4,000.00	\$ 20,000.00	80%	
2	Security Cameras Phase 3							\$64,000.00			\$16,000.00	\$ 80,000.00	80%	
3	Airfield paint removal, painting and crack sealing							\$240,000.00			\$60,000.00	\$ 300,000.00	80%	
4	Repair/replace entire drainage system near GA ramp back ramp and safety area for 3rd runway 7L on ALP							\$320,000.00			\$80,000.00	\$ 400,000.00	80%	
Total Planned Commitments for Future Projects							\$640,000.00	(State Entitlement Funds)	\$6,220,777.00	\$10,886,040.20	\$0.00	\$717,000.00	\$2,672,309.80	\$20,496,127.00

Funds Available \$469,591.16

Project Narratives

EUP #	Narrative
1	Plus up for line Airfield Lighting, Globes, Gaskets, Signage Panels, Windssocks, recent maintenance for Part 139 inspection revealed more sign panles and faulty wind sock pole that needs immediate repair. Prices for material have gone up
2	Plus up for line Security Cameras Phase 3 Initial estimate did not include cameras in main lobby, outside curb, and baggage claim to upgrade from analog cameras to digital and associated hardware and new cable and brackets
3	Plus up for line Airfield paint removal painting and crack sealing, recent RFP for eradication and repaint runway 7/25 came back significantly higher than anticipated due to higher paint and fuel costs. also recent Part 139 inspection identified runway 2/20 and other mandatory markings needed repainting
4	Current 20 inch corrugated pipe 1940's era approximately 1/4 mile long has collapsed in several locations causing large amounts of flooding of GA ramp area and taxi lanes. This is the main drain for the entire back ramp. PAC purchased 6 inch pump to assist but the pump cannot keep up when large rain falls occur. Recent claims from GA pilots have caused the airport to pay for damaged landing gear from water infiltration. Tree removal, excavation of entire drain line, to include the regrading of over 1 1/2 miles of smaller drain inlets that feed into the main drain will need to be addressed.
5	
6	
7	
8	
9	

As the Deputy Executive Director on behalf of the sponsor, I certify that the information provided above is accurate and complete to the best of my knowledge.



 Signature

 John J. Borden Jr.

 Printed Name
 VAB Package May 2022

As the Chief Financial Officer on behalf of the sponsor, I certify that the information provided above is accurate and complete to the best of my knowledge.



 Signature

 Mark J. Adams

 Printed Name
 4/25/2022 24







Aiming Point

Touchdown zone

Centerline

Threshold

27

PROJECT #4



Project # 4



Commonwealth Airport Fund Entitlement Utilization Report and Plan

Sponsor: **Capital Region Airport Commission**

Airport: **Richmond International**

Part 1 - Entitlement Utilization Report: FY2021

A. Entitlement Funds Available for Expenditure and Commitment

Total Funds Available for Commitment from FY2020	\$6,924,200.01
Entitlement Funds Received in FY2021	\$2,000,000.00
Interest Earned in FY2021	\$2,860.24
 Subtotal Entitlement Resources Available FY2021	 \$8,927,060.25

B. Reimbursement of State Entitlement Funds - PFC's; Bridge Loans; Other: FY2021

Project Description	AIP Project Number	DOAV Project Number	PFC Project Number	Funding Sources with Final Costs					Total Project Cost	State Funding Percentage	Reimbursement
				Federal	State Entitlement	State Discretionary	PFC	Local			
Subtotal Reimbursement of State Entitlement Funds											
\$0.00											

Total Funds Available \$8,927,060.25 (Entitlement Resources Available FY2021 + Reimbursement State Entitlement Funds)

C. Funding Expenditures for Projects Closed: FY2021

Project Description	AIP Project Number	DOAV Project Number	PFC Project Number	Funding Sources with Final Costs					Total Project Cost	State Funding Percentage	Estimated PFCs to Reimburse Entitlements
				Federal	State Entitlement	State Discretionary	PFC	Local			
Taxiway A South (Construction) 1798-13		CS0043-52	18 08 C 00	\$ -	\$ 1,705,704	\$ 346,750	\$ 514,248	\$ -	\$ 2,566,702	80%	
Taxiway L South (Design/Construction) 1798-08	AIP-064			\$ 3,801,643	\$ 422,405	\$ -	\$ -	\$ 91,081	\$ 4,315,129	10%	

Subtotal Expenditures for Projects Completed: FY2021 \$2,128,109.13 (State Entitlement Funds)

Unexpended Funds Available for Commitment \$6,798,951.12 (Total Funds Available - Expenditures for Completed Projects)

**Commonwealth Airport Fund
Entitlement Utilization Report and Plan**

D. Funding Commitments for Ongoing Projects

Project Description	Estimated Fiscal Year of Completion	AIP Project Number	DOAV Project Number	PFC Project Number	Funding Sources with Estimated Costs					Estimated Total Project Cost	Estimated State Funding Percentage	Estimated PFCs to Reimburse Entitlements
					Federal	State Entitlement	State Discretionary	PFC	Local			
800 Megahertz Radio System Replacement 1797-42	2022			18 08 C 00	\$ -	\$ 719,381	\$ -	\$ -	\$ 179,845	\$ 899,226	80%	
Airport Geographical Information System (GIS Phase II (FY17)) 1797-68	2022				\$ -	\$ 245,232	\$ -	\$ -	\$ 61,308	\$ 306,540	80%	
East Side Genral Aviation Apron 3 (Construction) 1798-16	2022				\$ -	\$ 1,671,153	\$ -	\$ -	\$ 417,788	\$ 2,088,941	80%	
Runway 7-25 Conversion to Taxiway H (Construction) 1798-15	2022	AIP-066	CF0043-66	18 08 C 00	\$ 8,542,101	\$ 691,344	\$ 67,454	\$ 189,824	\$ -	\$ 9,490,723	8%	
East Side Security Enhancements (Design/Construction) 1798-18	2022				\$ -	\$ 1,385,987	\$ -	\$ -	\$ 346,497	\$ 1,732,483	80%	
Obstruction Removal Clearing & Grubbing (D/C) 1797-57	2022				\$ -	\$ 475,733	\$ -	\$ -	\$ 118,199	\$ 594,666	80%	
Security Perimeter Road Widening (D/C) 1798-85	2022				\$ -	\$ 1,565,519	\$ -	\$ -	\$ 391,380	\$ 1,956,899	80%	
Concourse B Apron Expansion - Construction Phase Services	2022				\$ -	\$ 1,440,000	\$ -	\$ -	\$ 360,000	\$ 1,800,000	80%	
Concourse B Apron Expansion & Deicing Facility - Construction	2022	Pending			\$ 6,234,017	\$ 554,135	\$ -	\$ -	\$ 138,534	\$ 6,926,686	8%	

Subtotal Funding Commitments for Ongoing Projects \$8,748,483.76 (State Entitlement Funds)

Anticipated FY2022 Entitlement Funds (use last year's amount) \$2,000,000.00

Funds Available \$50,467.36 (Unexpended Funds Available for Commitment - Funding Commitments for Ongoing Projects + Anticipated FY2022 Entitlement Funds))

Part 2 - Entitlement Utilization Plan: FY2022

A. Project Listing

EUP #	Project Description	6-Year Plan Y / N	Estimated Start Date (Fiscal Year)	AIP Project Number	DOAV Project Number	PFC Project Number	Funding Sources with Estimated Costs					Estimated Total Project Cost	Estimated State Funding Percentage	Estimated PFCs to Reimburse Entitlements
							Federal	State Entitlement	State Discretionary	PFC	Local			
1.	Federal Inspection Services (Customs) Facility Renovation	Y	FY 2022	Pending	None	None	\$3,969,000	\$50,467	\$302,333	\$0	\$2,978,200	\$7,300,000	4.83%	\$0.00

Total Planned Commitments for Future Projects \$50,467.36 (State Entitlement Funds)

Funds Available \$0.00

**Commonwealth Airport Fund
Entitlement Utilization Report and Plan**

B. Project Narratives

EUP #	Narrative
1.	Renovation of the existing Federal Inspection Service Facility at the Richmond International Airport to meet current Customs and Border Protection standards. Renovation will include modifications to the structural, mechanical, electrical, plumbing, electronic and baggage handling systems.

Part 3 - Certification

As the President & CEO on behalf of the sponsor, I certify that the information provided above is accurate and complete to the best of my knowledge.

As the Director of Finance on behalf of the sponsor, I certify that the information provided above is accurate and complete to the best of my knowledge.



 Signature

 Perry J. Miller, A.A.E., I.A.P.
 Printed Name

 04/22/2022
 Date



 Signature

 Steven Owen, CPA
 Printed Name

 4/22/22
 Date

**Commonwealth Airport Fund
Entitlement Utilization Report and Plan**

Sponsor: Shenandoah Valley Regional Airport Commission
Shenandoah Valley Regional Airport

Airport: Shenandoah Valley Regional Airport

Part 1 - Entitlement Utilization Report: FY2021

A. Entitlement Funds Available for Expenditure and Commitment

Total Funds Available for Commitment from FY2020	\$635,631.05
Entitlement Funds Received in FY2021	\$2,000,000.00
Interest Earned in FY2021	\$1,616.84
 Subtotal Entitlement Resources Available FY2021	 \$2,637,247.89

B. Reimbursement of State Entitlement Funds - PFC's; Bridge Loans; Other: FY2021

Project Description	AIP Project Number	DOAV Project Number	PFC Project Number	Funding Sources with Final Costs					Total Project Cost	State Funding Percentage	Reimbursement
				Federal	State Entitlement	State Discretionary	PFC	Local			
									\$ -		
									\$ -		
									\$ -		

Subtotal Reimbursement of State Entitlement Funds \$0.00

Total Funds Available \$2,637,247.89 (Entitlement Resources Available FY2021 + Reimbursement of State Entitlement Funds)

C. Funding Expenditures for Projects Closed: FY2021

Project Description	AIP Project Number	DOAV Project Number	PFC Project Number	Funding Sources with Final Costs					Total Project Cost	State Funding Percentage	Estimated PFCs to Reimburse Entitlements
				Federal	State Entitlement	State Discretionary	PFC	Local			
Construct Hangars E & F -Site Design/Bidding	N/A				\$144,341.86			\$36,085.47	\$ 180,427.33	80%	
Install Secure Area Partition-Construction	N/A				\$202,292.38			\$50,573.09	\$ 252,865.47	80%	\$ 203,520.00
Vegetation Management	N/A				\$9,548.00			\$2,388.00	\$ 11,936.00	80%	
Metal Roof Repairs	N/A				\$9,365.30			\$2,534.70	\$ 11,900.00	78.7%	
AWOS Inspection and Repair	N/A				\$3,420.00			\$180.00	\$ 3,600.00	95%	
Taxiway K and Apron-Construction-Non Federal	3-51-0049-044				\$71,520.00			\$17,880.00	\$ 89,400.00	80%	
Environmental and Wetland Mitigation	N/A				\$28,202.89			\$7,050.73	\$ 35,253.62	80%	
Repair E-One Pump	N/A				\$4,034.04			\$1,008.51	\$ 5,042.55	80%	
Repair GA Roof AC unit	N/A				\$2,160.26			\$584.66	\$ 2,744.92	78.7%	
Repair AC Terminal Boiler	N/A				\$1,731.60			\$1,388.40	\$ 3,120.00	55.5%	
Repair AC Terminal Boiler	N/A				\$2,028.18			\$1,626.20	\$ 3,654.38	55.5%	
Repairs to Snow Removal Equipment	N/A				\$2,531.78			\$632.93	\$ 3,164.71	80%	
Repairs to Bumper Turret-Oshkosh Striker	N/A				\$857.16			\$214.29	\$ 1,071.45	80%	
Repairs to GA Terminal Women's Restroom	N/A				\$3,103.93			\$840.07	\$ 3,944.00	78.7%	
Evaluate PAPs	N/A				\$1,244.50			\$65.50	\$ 1,310.00	95%	

**Commonwealth Airport Fund
Entitlement Utilization Report and Plan**

Evaluate Runway/Taxiway Light Outage	N/A				\$1,406.00			\$74.00	\$ 1,480.00	95%	
--------------------------------------	-----	--	--	--	------------	--	--	---------	-------------	-----	--

Subtotal Expenditures for Projects Completed: FY2021 \$487,787.88 (State Entitlement Funds)

Unexpended Funds Available for Commitment \$2,149,460.01 (Total Funds Available - Expenditures for Completed Projects)

**Commonwealth Airport Fund
Entitlement Utilization Report and Plan**

D. Funding Commitments for Ongoing Projects

Project Description	Estimated Fiscal Year of Completion	AIP Project Number	DOAV Project Number	PFC Project Number	Funding Sources with Estimated Costs					Estimated Total Project Cost	Estimated State Funding Percentage	Estimated PFCs to Reimburse Entitlements	
					Federal	State Entitlement	State Discretionary	PFC	Local				
Remove and Replace Fuel Farm Tanks	2022					\$189,916.14				\$585,083.86	\$ 775,000.00	33.3%	
Construct Hangars E & F Site-Construction	2022					\$447,960.00				\$111,991.20	\$ 559,951.20	80%	
Replace Boiler in AC Terminal	2022					\$24,975.00				\$20,025.00	\$ 45,000.00	55.5%	
Remark Runway	2022					\$16,000.00				\$4,000.00	\$ 20,000.00	80%	
Land Acquisition Services	2022					\$52,800.00				\$13,200.00	\$ 66,000.00	80%	
Land Acquisition Parcel 37B	2022					\$798,800.00				\$199,700.00	\$ 998,500.00	80%	
Loading Ramp	2022					\$64,000.00				\$16,000.00	\$ 80,000.00	80%	
Landscape & Signage	2022					\$50,000.00				\$50,000.00	\$ 100,000.00	50%	
Parking Lot Sealcoat & remarking-Design	2022					\$38,531.50				\$11,968.50	\$ 50,500.00	76.3%	
Drainage-Design	2022					\$20,000.00				\$5,000.00	\$ 25,000.00	80%	
Drainage-Construction	2022					\$80,000.00				\$20,000.00	\$ 100,000.00	80%	
Communication Tower	2022					\$7,800.00				\$11,700.00	\$ 19,500.00	40%	
Building and Facilities Maintenance	2022					\$60,000.00				\$15,000.00	\$ 75,000.00	80%	
Equipment Maintenance	2022					\$40,000.00				\$10,000.00	\$ 50,000.00	80%	
AWOS Inspection and Repair	2022					\$3,420.00				\$180.00	\$ 3,600.00	95%	
Vegetation Management	2022					\$13,456.00				\$3,364.00	\$ 16,820.00	80%	
Mower & Deck	2022					\$25,695.96				\$6,423.99	\$ 32,119.95	80%	
Snow Blade	2022					\$21,680.00				\$5,420.00	\$ 27,100.00	80%	

Subtotal Funding Commitments for Ongoing Projects \$1,955,034.60 (State Entitlement Funds)

Anticipated FY2022 Entitlement Funds (use last year's amount) \$1,320,800.59

Funds Available \$1,515,226.00 (Unexpended Funds Available for Commitment - Funding Commitments for Ongoing Projects + Anticipated FY2022 Entitlement Funds)

Part 2 - Entitlement Utilization Plan: FY2022

A. Project Listing

EUP #	Project Description	6-Year Plan Y / N	Estimated Start Date (Fiscal Year)	AIP Project Number	DOAV Project Number	PFC Project Number	Funding Sources with Estimated Costs					Estimated Total Project Cost	Estimated State Funding Percentage	Estimated PFCs to Reimburse Entitlements
							Federal	State Entitlement	State Discretionary	PFC	Local			
15	Increase Equipment Maintenance	N	2022					\$20,000.00			\$5,000.00	\$25,000.00	80%	
16	Land Acquisition Services Phase I	Y	2022					\$216,000.00			\$54,000.00	\$270,000.00	80%	
17	Rehabilitate Rwy 5-23-Construction	Y	2023	Pending			\$6,650,000.00	\$350,000.00				\$7,000,000.00	5%	
18	Hangar E & F Site Work-Construction	N	2022					\$341,360.00			\$85,340.00	\$426,700.00	80%	

Total Planned Commitments for Future Projects \$927,360.00 (State Entitlement Funds)

Funds Available \$587,866.00

B. Project Narratives
VAB Package May 2022

Commonwealth Airport Fund
Entitlement Utilization Report and Plan

4/7/22
Date

4/7/2022
Date





**CONSTRUCT
ACCESS ROAD**

**CONSTRUCT
PARKING LOTS**

RELOCATED WATER AND
SANITARY SEWER LINES
BY OTHERS

FUTURE HANGARS E AND F
(2022)

RECENTLY COMPLETED
TAXIWAY K AND APRON



HANGAR PARKING LOT ACCESS ROAD SHENANDOAH VALLEY REGIONAL AIRPORT

EXHIBIT
1 40

DRAWING: 18054_exh-project scope.dwg LAYOUT: L1



DRAWN BY: SKN CHECKED BY: JCL SCALE: 1" = 100' DATE: JANUARY 2021

COMMERCIAL AIRPORTS - ENTITLEMENT FUND
RECOMMENDED PROJECTS
STATEWIDE REPORT

FUNDED

PRIORITY NO.	AIRPORT NAME	DESCRIPTION	FEDERAL AMOUNT	STATE ENTITL. AMOUNT	STATE DISCR. AMOUNT	LOCAL AMOUNT	TOTAL PROJECT AMOUNT
193	Richmond International Airport	Federal Inspection Service Facility Renovation (Construction)	\$3,969,000.00	\$50,467.36	\$302,332.64	\$2,978,200.00	\$7,300,000.00

FUNDING TOTALS:	\$3,969,000.00	\$50,467.36	\$302,332.64	\$2,978,200.00	\$7,300,000.00
-----------------	----------------	-------------	--------------	----------------	----------------

TOTAL ALLOCATION OF STATE ENTITLEMENT FUNDS: \$50,467.36
 ADDITIONAL DISCRETIONARY REQUESTED: \$302,332.64

SUMMARY FUNDING TOTALS:			\$3,969,000.00	\$50,467.36	\$302,332.64	\$2,978,200.00	\$7,300,000.00
-------------------------	--	--	----------------	-------------	--------------	----------------	----------------

AIR CARRIER / RELIEVER AIRPORTS - DISCRETIONARY FUNDS
RECOMMENDED PROJECTS
STATEWIDE

FUNDED

PRIORITY NO.	AIRPORT NAME	DESCRIPTION	FEDERAL AMOUNT	STATE DISCR. AMOUNT	LOCAL AMOUNT	TOTAL PROJECT AMOUNT
193	Richmond International Airport	Federal Inspection Service Facility Renovation (Construction)	\$3,969,000.00	\$302,332.64	\$2,978,200.00	\$7,300,000.00
190	Hampton Roads Executive Airport	Runway 10-28 Re-Marking (Construction)	\$0.00	\$71,957.00	\$17,990.04	\$89,947.04
189	Hampton Roads Executive Airport	T-Hangar Taxilanes Crack Fill & Sealcoat (Construction)	\$0.00	\$88,564.00	\$22,141.34	\$110,705.34
187	Lake Country Regional Airport	East and West Side Runway Obstruction Survey and Removal	\$0.00	\$10,240.00	\$2,560.00	\$12,800.00
186	Hanover County Municipal Airport	West Apron Rehabilitation - Phase 1 (Construction)	\$0.00	\$120,000.00	\$30,000.00	\$150,000.00
184	Stafford Regional Airport	Runway 15 Extension - Phase 2 (AIP) - CHANGE ORDER	\$916,875.00	\$81,500.00	\$20,375.00	\$1,018,750.00
177	Twin County Airport	Rotating Beacon Replacement	\$0.00	\$12,012.00	\$3,004.00	\$15,016.00
171	Blue Ridge Regional Airport	West Apron Crack Fill & Sealcoat (Construction)	\$0.00	\$34,305.00	\$8,577.00	\$42,882.00
170	Gordonsville Municipal Airport	Runway, Taxiway & Apron Rehabilitation (Construction) - INCREASE	\$0.00	\$273,082.00	\$68,271.00	\$341,353.00
165	Hampton Roads Executive Airport	West Apron Hangar Site Preparation (Construction) - INCREASE	\$0.00	\$296,457.33	\$74,114.33	\$370,571.66
162	Tappahannock-Essex County Airport	Rotating Beacon Replacement	\$0.00	\$13,584.00	\$3,396.00	\$16,980.00
153	Stafford Regional Airport	Fueling System Upgrade - Reclaimed Fuel Vessels (Construction)	\$0.00	\$1,511.00	\$3,069.16	\$4,580.16
148	Virginia Tech - Montgomery Executive Airport	Slope Mower	\$0.00	\$17,623.75	\$17,623.75	\$35,247.50
147	Lake Country Regional Airport	Security Camera System	\$0.00	\$3,240.00	\$360.00	\$3,600.00
143	Tappahannock-Essex County Airport	Terminal Building HVAC Replacement (Construction)	\$0.00	\$23,160.00	\$5,790.00	\$28,950.00
129	Middle Peninsula Regional Airport	Main Apron & Mid-Field Taxiway Rehabilitation (Design)	\$162,000.00	\$14,400.00	\$3,600.00	\$180,000.00
125	Louisa County Airport	South Side Taxiway (Design)	\$184,500.00	\$16,400.00	\$4,100.00	\$205,000.00
121	Leesburg Executive Airport	Hangars A, B, C & D Taxilanes Rehabilitation (Design)	\$0.00	\$104,000.00	\$26,000.00	\$130,000.00
115	Lee County Airport	Runway 7-25 Airfield Lighting Rehabilitation (Design)	\$106,200.00	\$9,440.00	\$2,360.00	\$118,000.00
110	Stafford Regional Airport	T-Hangars 6, 7 & 8 Site Preparation (Design)	\$0.00	\$136,000.00	\$34,000.00	\$170,000.00
85	Culpeper Regional Airport	East Side Terminal Area Plan	\$0.00	\$82,937.00	\$20,735.00	\$103,672.00
FUNDING TOTALS:			\$5,338,575.00	\$1,712,745.72	\$3,346,266.62	\$10,448,054.70

AVAILABLE DOLLARS FOR THE VAB TO COMMIT: \$10,728,306.45

VAB Package May 2022 BALANCE: \$9,015,560.73

AIR CARRIER / RELIEVER AIRPORTS - DISCRETIONARY FUNDS
 NOT RECOMMENDED PROJECTS
 STATEWIDE

Not Recommended

PRIORITY NO.	AIRPORT NAME	DESCRIPTION	FEDERAL AMOUNT	STATE DISCR. AMOUNT	LOCAL AMOUNT	TOTAL PROJECT AMOUNT
95	Suffolk Executive Airport	T-Hangar G Site Preparation (Design)	\$0.00	\$0.00	\$140,000.00	\$140,000.00
FUNDING TOTALS:			\$0.00	\$0.00	\$140,000.00	\$140,000.00

This page intentionally left blank.

COMMONWEALTH AVIATION FUND ALLOCATION STATUS

For the FYE June 30, 2022

as of July 7, 2021

updated 4/13/22 MS

AIRPORT TENTATIVE ALLOCATION STATUS

AIRPORT	DESCRIPTION	DATE	FAA FY	PROJECT #	DISCRETIONARY	GRANT	T.A. BALANCE
ACCOMACK COUNTY (GA-R)	RUNWAY 21 TURNAROUND (DES)	MAR 18, 21		XXXXXXXX	6,000.00		
	SPONSOR RETURN-RUNWAY 21 TURNAROUND (DES)	OCT 14, 21		XXXXXXXX	(6,000.00)		
	RUNWAY 21 TURAROUND (CON)	FEB 3, 22			45,600.00		45,600.00
ALLEN C. PERKINSON / BLACKSTONE AAF (GA-C) (NON-NPIAS)	APRON REHABILITATION (DES)	JUN 17, 21		CS0008-11	40,000.00		
	GRANT-APRON REHABILITATION (DES)	JUL 7, 21		CS0008-11		40,000.00	
	APRON REHABILITATION (CON)	FEB 3, 22		CS0008-12	458,400.00		
	GRANT-APRON REHABILITATION (CON)	MAR 14, 22		CS0008-12		458,400.00	0.00
BLUE RIDGE (GA-R)	VAB INCREASE-LAND AQUIS SERVICES RWY 13 RPZ/PART 77-BRIDGE LOAN	FEB 3, 22		CS0032-22	9,116.00		
	AMEND 1-LAND AQUIS SERVICES RWY 13 RPZ/PART 77-BRIDGE LOAN	FEB 23, 22		CS0032-22		9,116.00	0.00
BRIDGEWATER AIR PARK (GA-L) (NON-NPIAS)	RUNWAY/TAXIWAYS CRACK SEAL, SEAL COAT, & REMARKING (CON)	FEB 3, 22		CS9072-11	136,000.00		
	GRANT-RUNWAY/TAXIWAYS CRACK SEAL, SEAL COAT, & REMARKING (CON)	MAR 21, 22		CS9072-11		136,000.00	0.00
BROOKNEAL/CAMPBELL COUNTY (GA-C)							
CHARLOTTESVILLE-ALBEMARLE (AC-N)							
CHASE CITY (GA-L) (NON-NPIAS)							
CHESAPEAKE REGIONAL (REL)	TERMINAL BUILDING RESTROOMS RENOVATION	JUN 17, 21		CS0006-57	5,543.00		
	GRANT-TERMINAL BUILDING RESTROOMS RENOVATION	JUL 19, 21		CS0006-57		5,543.00	
	T-HANGARS TAXILANES REHABILITATION-PH 2 (CON)	AUG 19, 21		CS0006-58	842,400.00		
	GRANT-T-HANGARS TAXILANES REHABILITATION-PH 2 (CON)	OCT 6, 21		CS0006-58		842,400.00	
	AWOS VISIBILITY SENSOR REPLACEMENT	FEB 3, 22		CS0006-59	21,873.00		
	GRANT-AWOS VISIBILITY SENSOR REPLACEMENT	FEB 14, 22		CS0006-59		21,873.00	
	RUNWAY & TAXIWAY LIGHTING REHAB (CON)	FEB 3, 22			100,000.00		100,000.00
CREWE MUNICIPAL (GA-L) (NON-NPIAS)							
CULPEPER REGIONAL (GA-R)	APRON LIGHTING-PHASE 2 (CON)	AUG 19, 21		CS0010-30	187,068.00		
	GRANT-APRON LIGHTING-PHASE 2 (CON)	AUG 31, 21		CS0010-30		187,068.00	
	GREENHOUSE ROAD EXTENSION (CON) (AIP)	FEB 3, 22			257,777.00		
	GREENHOUSE ROAD EXTENSION (CON) (NON-AIP)-BRIDGE LOAN	FEB 3, 22			557,097.00		814,874.00
DANVILLE REGIONAL (GA-R)	BOX HANGAR SITE PREPARATION (DES)	JUN 17, 21		CS0011-49	71,116.00		
	GRANT-BOX HANGAR SITE PREPARATION (DES)	JUL 12, 21		CS0011-49		71,116.00	

VAB Package May 2022

45

COMMONWEALTH AVIATION FUND ALLOCATION STATUS

For the FYE June 30, 2022

as of July 7, 2021

updated 4/13/22 MS

AIRPORT TENTATIVE ALLOCATION STATUS

AIRPORT	DESCRIPTION	DATE	FAA FY	PROJECT #	DISCRETIONARY	GRANT	T.A. BALANCE
	AIRFIELD DIRECTIONAL SIGN REPLACEMENT (CON)	FEB 3, 22		CS0011-50	4,544.00		
	GRANT-AIRFIELD DIRECTIONAL SIGN REPLACEMENT (CON)	MAR 14, 22		CS0011-50		4,544.00	
	ACCESS CONTROL & REPLACEMENT AUTO GATE (CON)	FEB 3, 22		CS0011-54	31,129.00		
	GRANT-ACCESS CONTROL & REPLACEMENT AUTO GATE (CON)	MAR 14, 22		CS0011-54		31,129.00	
	ADMIN INCR-ACCESS CONTROL & REPLACEMENT AUTO GATE (CON)	APR 13, 22			1,558.00		
	TERMINAL BUILDING RENOVATION (CON)	FEB 3, 22		CS0011-52	834,928.00		
	GRANT-TERMINAL BUILDING RENOVATION (CON)	FEB 22, 22		CS0011-52		834,928.00	
	TERMINAL BUILDING REPLACEMENT FURNITURE	FEB 3, 22		CS0011-53	42,434.00		
	GRANT-TERMINAL BUILDING REPLACEMENT FURNITURE	MAR 14, 22		CS0011-53		42,434.00	
	SOUTH RAMP REHAB-PH 1 (CON)	FEB 3, 22			160,000.00		
	FUELING SYSTEM MODIFICATION (DES)	FEB 3, 22		CS0011-51	36,660.00		
	GRANT-FUELING SYSTEM MODIFICATION (DES)	MAR 14, 22		CS0011-51		36,660.00	161,558.00
DINWIDDIE COUNTY (GA-R)	TERMINAL BUILDING ROOF REPLACEMENT (CON)	DEC 2, 21		CS0039-36	21,600.00		
	GRANT-TERMINAL BUILDING ROOF REPLACEMENT (CON)	JAN 4, 22		CS0039-36		21,600.00	0.00
EAGLE'S NEST (GA-L) (NON-NPIAS)							
EMPORIA-GREENSVILLE (GA-R)	TAXIWAY & APRON REHAB-PH 1 (CON)	FEB 3, 22			16,000.00		16,000.00
FALWELL (GA-L) (NON-NPIAS)							
FARMVILLE MUNICIPAL (GA-R)	RUNWAY SAFETY AREA GRADING (CON)	AUG 19, 21		XXXXXXXXXX	119,444.00		
	SPONSOR RETURN-RUNWAY SAFETY AREA GRADING (CON)	OCT 19, 21		XXXXXXXXXX	(119,444.00)		0.00
FRANKLIN MUNICIPAL (GA-C)	APRON SINKHOLE REPAIR (CON)	JUN 17, 21		CS0017-15	11,600.00		
	GRANT-APRON SINKHOLE REPAIR (CON)	NOV 9, 21		CS0017-15		11,600.00	0.00
FRONT ROYAL/WARREN COUNTY (GA-C)	TERMINAL BUILDING ROOF REPLACEMENT (CON)	AUG 19, 21		CS0019-23	67,626.00		
	GRANT-TERMINAL BUILDING ROOF REPLACEMENT (CON)	SEP 7, 21		CS0019-23		67,626.00	0.00
GORDONSVILLE MUNICIPAL (GA-L) (NON-NPIAS)							
GRUNDY (GA-L) (PROPOSED)	NPIAS JUSTIFICATION STUDY	JUN 17, 21		CS0022-01	129,213.00		
	GRANT-NPIAS JUSTIFICATION STUDY	JUL 7, 21		CS0022-01		129,213.00	0.00
HAMPTON ROADS AIRPORT (REL)	WEST APRON TAXIWAYS REHABILITATION (CON)	MAR 18, 21		XXXXXXXXXX	40,000.00		
	SPONSOR RETURN-WEST APRON TAXIWAYS REHABILITATION (CON)	NOV 9, 21		XXXXXXXXXX	(40,000.00)		
	APRON & WASH RACK (CON)	AUG 19, 21		CS0040-57	888,000.00		
	GRANT-APRON & WASH RACK (CON)	SEP 7, 21		CS0040-57		888,000.00	46

VAB Package May 2022

COMMONWEALTH AVIATION FUND ALLOCATION STATUS

For the FYE June 30, 2022

as of July 7, 2021

updated 4/13/22 MS

AIRPORT TENTATIVE ALLOCATION STATUS

AIRPORT	DESCRIPTION	DATE	FAA FY	PROJECT #	DISCRETIONARY	GRANT	T.A. BALANCE
	VAB INCREASE-WASH RACK (DES)	AUG 19, 21		CS0040-49	3,842.00		
	AMENDMENT 2-WASH RACK (DES)	SEP 7, 21		CS0040-49		3,842.00	
	VAB INCR-FUELING SYSTEM (DES)	DEC 2, 21		CS0040-50	1,584.00		
	AMEND 3-FUELING SYSTEM (DES)	DEC 16, 21		CS0040-50		1,584.00	
	FUELING SYSTEM EXPANSION (CON)	FEB 3, 22		CS0040-58	132,000.00		
	GRANT-FUELING SYSTEM EXPANSION (CON)	FEB 16, 22		CS0040-58		132,000.00	
	WEST APRON TAXIWAYS REHAB-PH 2 (CON)	FEB 3, 22			40,000.00		40,000.00
HANOVER COUNTY (REL)	RUNWAY 16-34 REHABILITATION (DES)	MAR 18, 21		XXXXXXXXXX	32,000.00		
	SPONSOR RETURN-RUNWAY 16-34 REHABILITATION (DES)	OCT 12, 21		XXXXXXXXXX	(32,000.00)		
	TERMINAL BUILDING FURNITURE	JUN 17, 21		CS0023-45	41,126.00		
	GRANT-TERMINAL BUILDING FURNITURE	JUL 12, 21		CS0023-45		41,126.00	
	EAST SIDE PERIMETER FENCING-PH 1 (CON)	DEC 2, 21		CS0023-46	18,603.00		
	GRANT-EAST SIDE PERIMETER FENCING-PH 1 (CON)	JAN 18, 22		CS0023-46		18,603.00	
	EAST SIDE PERIMETER FENCING-PH 2 (CON)	FEB 3, 22		CS0023-47	52,380.00		
	GRANT-EAST SIDE PERIMETER FENCING-PH 2 (CON)	FEB 22, 22		CS0023-47		52,380.00	0.00
HUMMEL FIELD (GA-L) (NON-NPIAS)	ENVIRONMENTAL IMPACT REVIEW-RUNWAY REALIGNMENT	DEC 2, 21		CS0076-20	31,920.00		
	GRANT-ENVIRONMENTAL IMPACT REVIEW-RUNWAY REALIGNMENT	JAN 18, 22		CS0076-20		31,920.00	0.00
INGALLS FIELD (GA-R)							
JAMES CITY COUNTY / JGG	VAB INCREASE-ACCESS ROAD REHABILITATION/REALIGNMENT (CON)	AUG 19, 21		CS0086-02	79,408.91		
	REALLOCATED TO WILLIAMSBURG-JAMESTOWN	OCT 4, 21		CS0086-02	(9,132.80)		
	AMEND 2-ACCESS ROAD REHABILITATION/REALIGNMENT (CON)	JAN 26, 22		CS0086-02		70,276.11	0.00
LAKE ANNA (GA-L) (NON-NPIAS)							
LAKE COUNTRY (GA-C) (NON-NPIAS)	RUNWAY REHAB & RSA IMPROVEMENT-PH 4 (CON)	FEB 3, 22		CS9060-22	1,236,000.00		
	GRANT-RUNWAY REHAB & RSA IMPROVEMENT-PH 4 (CON)	MAR 21, 22		CS9060-22		1,236,000.00	0.00
LAWRENCEVILLE-BRUNSWICK (GA-L) (NON-NPIAS)							
LEE COUNTY (GA-C)	CRACK SEAL, SEALCOAT, & PAVEMENT REMARKING	JUN 17, 21		XXXXXXXXXX	30,133.00		
	SPONSOR RETURN-CRACK SEAL, SEALCOAT, & PAVEMENT REMARKING	OCT 14, 21		XXXXXXXXXX	(30,133.00)		
	FUELING SYSTEM EXPANSION-JET A TANK (CON)	FEB 3, 22		CS0084-10	65,878.00		
	GRANT-FUELING SYSTEM EXPANSION-JET A TANK (CON)	MAR 9, 22		CS0084-10		65,878.00	0.00
LEESBURG EXECUTIVE (REL)	HANGAR SITE PREPARATION (CON) (NON-AIP)	JUN 17, 21		CS0027-43	204,800.00		
	GRANT-HANGAR SITE PREPARATION (CON) (NON-AIP)	JAN 4, 22		CS0027-43		204,800.00	47

VAB Package May 2022

COMMONWEALTH AVIATION FUND ALLOCATION STATUS

For the FYE June 30, 2022

as of July 7, 2021

updated 4/13/22 MS

AIRPORT TENTATIVE ALLOCATION STATUS

AIRPORT	DESCRIPTION	DATE	FAA FY	PROJECT #	DISCRETIONARY	GRANT	T.A. BALANCE
	ADMIN INCR-TERMINAL ENTRANCE ROAD REHAB (CON)	JUL 28, 21		CS0027-42	2,930.78		
	AMEND 1-TERMINAL ENTRANCE ROAD REHAB (CON)	AUG 16, 21		CS0027-42		2,930.78	
	ADMIN INCR-NORTH END DEVELOPMENT SITE PREPARATION (DESIGN)	AUG 16, 21		CF0027-42	1,520.73		
	AMEND 1-NORTH END DEVELOPMENT SITE PREPARATION (DESIGN)	OCT 25, 21		CF0027-42		1,520.73	
	NORTH APRON CRACK SEAL & SEAL COAT (CON)	FEB 3, 22		CS0027-44	40,405.00		
	ADMIN INCR-NORTH APRON CRACK SEAL & SEAL COAT (CON)	FEB 3, 22		CS0027-44	100.00	40,505.00	0.00
	GRANT-NORTH APRON CRACK SEAL & SEAL COAT (CON)	MAR 15, 22		CS0027-44			
LONESOME PINE (GA-R)	RUNWAY 6-24 REHABILITATION (CON)	MAR 18, 21		XXXXXXXX	480,000.00		
	SPONSOR RETURN-RUNWAY 6-24 REHABILITATION (CON)	NOV 8, 21		XXXXXXXX	(480,000.00)		
	SPCCP	DEC 2, 21		CS0060-16	3,781.00		
	GRANT-SPCCP	JAN 14, 22		CS0060-16		3,781.00	0.00
LOUISA COUNTY (GA-R)							
LUNENBURG COUNTY (GA-L) (NON-NIPIAS)	RUNWAY & APRON REHAB (PRELIM ENGIN)	DEC 2, 21		CS0025-10	17,600.00		
	GRANT-RUNWAY & APRON REHAB (PRELIM ENGIN)	DEC 13, 21		CS0025-10		17,600.00	0.00
LURAY CAVERNS (GA-C)	TERMINAL BUILDING (DES)	MAR 18, 21		CS0067-18	144,000.00		
	GRANT-TERMINAL BUILDING (DES)	JUL 26, 21		CS0067-18		144,000.00	
	ROTATING BEACON REPLACEMENT	JUN 17, 21		CS0067-20	7,316.00		
	GRANT-ROTATING BEACON REPLACEMENT	JUL 12, 21		CS0067-20		7,316.00	
	T-HANGARS & TAXILANE SITE PREPARATION (DES)	AUG 19, 21		CS0067-21	75,000.00		
	GRANT-T-HANGARS & TAXILANE SITE PREPARATION (DES)	SEP 7, 21		CS0067-21		75,000.00	0.00
LYNCHBURG REGIONAL (AC-N)							
MANASSAS REGIONAL (REL)	MASTER PLAN UPDATE	MAR 18, 21		XXXXXXXX	48,000.00		
	SPONSOR RETURN-MASTER PLAN UPDATE	OCT 18, 21		XXXXXXXX	(48,000.00)		
	T-HANGAR TAXIWAY REHABILITATION (CON)	JUN 17, 21		CS0030-41	76,763.00		
	GRANT-T-HANGAR TAXIWAY REHABILITATION (CON)	JUL 26, 21		CS0030-41		76,763.00	
	TERMINAL BUILDING BOILER REPLACEMENT	JUN 17, 21		CS0030-42	38,642.00		
	GRANT-TERMINAL BUILDING BOILER REPLACEMENT	JUL 26, 21		CS0030-42		38,642.00	
	RUNWAY 16L-34R REMARKING (CON)	AUG 19, 21		CS0030-43	37,780.00		
	GRANT-RUNWAY 16L-34R REMARKING (CON)	SEP 27, 21		CS0030-43		37,780.00	
	TAXIWAY 'A' PAVEMENT 7 LIGHTING REHAB (CON)	FEB 3, 22			240,000.00		240,000.00
MECKLENBURG/BRUNSWICK REGIONAL (GA-R)	HELICOPTER PARKING APRON & HANGAR TAXIWAYS (DES)	AUG 19, 21		XXXXXXXX	15,200.00		
	SPONSOR RETURN-HELICOPTER PARKING APRON & HANGAR TAXIWAYS	NOV 9, 21		XXXXXXXX	(15,200.00)		0.00

COMMONWEALTH AVIATION FUND ALLOCATION STATUS

For the FYE June 30, 2022

as of July 7, 2021

updated 4/13/22 MS

AIRPORT TENTATIVE ALLOCATION STATUS

AIRPORT	DESCRIPTION	DATE	FAA FY	PROJECT #	DISCRETIONARY	GRANT	T.A. BALANCE
MIDDLE PENINSULA REGIONAL (GA-R)	ENVIRONMENTAL COORD-ACCESS ROAD & BOX HANGAR SITE PREP	AUG 19, 21		CS0057-42	22,400.00		
	GRANT-ENVIRONMENTAL COORD-ACCESS ROAD & BOX HANGAR SITE P	SEP 20, 21		CS0057-42		22,400.00	0.00
MOUNTAIN EMPIRE (GA-C)	OBSTRUCTION LIGHTING REPLACEMENT (CON)	JUN 17, 21		CS0031-35	3,568.00		
	GRANT-OBSTRUCTION LIGHTING REPLACEMENT (CON)	AUG 16, 21		CS0031-35		3,568.00	
	OBSTRUCTION REMOVAL-ROFA GRADING (DES)	JUN 17, 21		XXXXXXXXXX	22,000.00		
	SPONSOR RETURN-OBSTRUCTION REMOVAL-ROFA GRADING (DES)	OCT 13, 21		XXXXXXXXXX	(22,000.00)		
	FUELING SYSTEM TANK REPAINTING (CON)	DEC 2, 21		CS0031-36	3,531.00		
	GRANT-FUELING SYSTEM TANK REPAINTING (CON)	JAN 26, 22		CS0031-36		3,531.00	0.00
NEW KENT COUNTY (GA-C)	FUELING SYSTEM REPAIR (PUMP) (CON)	DEC 2, 21		CS0041-17	5,988.00		
	GRANT-FUELING SYSTEM REPAIR (PUMP) (CON)	JAN 24, 22		CS0041-17		5,988.00	0.00
NEW LONDON (GA-L) (NON-NPIAS)							
NEW MARKET (GA-L) (NON-NPIAS)							
NEWPORT NEWS/WILLIAMSBURG INT'L (AC-S)							
NEW RIVER VALLEY (GA-R)	MASTER PLAN UPDATE	MAR 18, 21		XXXXXXXXXX	40,000.00		
	SPONSOR RETURN-MASTER PLAN UPDATE	OCT 18, 21		XXXXXXXXXX	(40,000.00)		
	TAXIWAY CRACK SEAL (CON)	AUG 19, 21		CS0012-10	29,600.00		
	GRANT-TAXIWAY CRACK SEAL (CON)	SEP 7, 21		CS0012-10		29,600.00	
	ADMIN INCR-TAXIWAY CRACK SEAL (CON)	SEP 14, 21		CS0012-10	560.00		
	AMENDMENT 1-TAXIWAY CRACK SEAL (CON)	OCT 4, 21		CS0012-10		560.00	
	ADMIN INCR-PARKING LOT REHABILITATION (DES/CON)	SEP 14, 21		CS0012-09	838.19		
	AMENDMENT 1-PARKING LOT REHABILITATION (DES/CON)	OCT 4, 21		CS0012-09		838.19	
	HANGAR SITE PREPARATION (DES)	FEB 28, 22		CS0012-11	45,063.00		
	RETURN EXCESS-HANGAR SITE PREPARATION (DES)	FEB 28, 22		CS0012-11	(1.00)		
	GRANT-HANGAR SITE PREPARATION (DES)	FEB 28, 22		CS0012-11		45,062.00	0.00
NORFOLK INT'L (AC-S)							
ORANGE COUNTY (GA-C)							
RICHMOND EXEC-CHESTERFIELD CO (REL)	SOUTHEAST APRON EXPANSION (DES)	JUN 17, 21		CS0007-47	168,480.00		
	VAB INCR-SOUTHEAST APRON EXPANSION (DES) & CHANGE SCOPE	DEC 2, 21		CS0007-47	161,520.00		
	GRANT-SOUTHEAST APRON EXPANSION (DES)	JAN 31, 22		CS0007-47		330,000.00	
	SOUTHEAST BOX HANGARS SITE PREPARATION (DES)	JUN 17, 21			132,165.00		
VAB Package May 2022	TERMINAL APRON REHABILITATION (DES)	AUG 19, 21		XXXXXXXXXX	13,480.00		

COMMONWEALTH AVIATION FUND ALLOCATION STATUS

For the FYE June 30, 2022

as of July 7, 2021

updated 4/13/22 MS

AIRPORT TENTATIVE ALLOCATION STATUS

AIRPORT	DESCRIPTION	DATE	FAA FY	PROJECT #	DISCRETIONARY	GRANT	T.A. BALANCE
	SPONSOR RETURN-TERMINAL APRON REHABILITATION (DES)	OCT 13, 21		XXXXXXXX	(13,480.00)		
	VAB INCREASE-ACCESS ROAD REHAB (DES)	FEB 3, 22		CS0007-45	25,200.00		
	AMENDMENT 1-ACCESS ROAD REHAB (DES)	MAR 9, 22		CS0007-45		25,200.00	132,165.00
RICHMOND INTERNATIONAL (AC-S)							
SHANNON (GA-C)							
SHENANDOAH VALLEY (AC-S)	LAND ACQUISITION (PARCEL 37B) (\$798,800 E)	AUG 19, 21					0.00
SMITH MOUNTAIN LAKE (NON-NPIAS)							
STAFFORD COUNTY (REL)	RUNWAY EXTENSION-PHASE 2 (CON)	MAR 18, 21		XXXXXXXX	464,000.00		
	SPONSOR RETURN-RUNWAY EXTENSION-PHASE 2 (CON)	OCT 18, 21		XXXXXXXX	(464,000.00)		0.00
SUFFOLK (GA-R)	VAB INCREASE-EASEMENT ACQUISITION SERVICES-OBST REMOVAL-BL	AUG 19, 21		CS0050-42	36,860.00		
	AMEND 1-EASEMENT ACQUISITION SERVICES-OBST REMOVAL-BL	SEP 27, 21		CS0050-42		36,860.00	
	TERMINAL APRON REHAB (CON)	FEB 3, 22			204,800.00		204,800.00
TANGIER ISLAND (GA-C)							
TAPPAHANNOCK - ESSEX COUNTY (GA-R)							
TAZEWELL COUNTY (GA-R)	VAB INCREASE-EASEMENT ACQUISITION SERVICES-OBST REMOVAL-BL	AUG 19, 21		CS0053-34	11,520.00		
	AMEND 1-EASEMENT ACQUISITION SERVICES-OBST REMOVAL-BL	AUG 31, 21		CS0053-34		11,520.00	0.00
TWIN COUNTY (GA-C)	TERMINAL BUILDING SECURITY CAMERAS REPLACEMENT	JUN 17, 21		CS0020-29	3,577.00		
	GRANT-TERMINAL BUILDING SECURITY CAMERAS REPLACEMENT	JUL 27, 21		CS0020-29		3,577.00	0.00
VIRGINIA HIGHLANDS (GA-R)	RUNWAY 6-24 EXTENSION-PHASE 5 (EMBANKMENT SEASON 3)	MAR 18, 21		XXXXXXXX	334,000.00		
	SPONSOR RET-RWY 6-24 EXTEN-PHASE 5 (EMBANKMENT SEASON 3)	OCT 13, 21		XXXXXXXX	(334,000.00)		
	SINKHOLE & DRAINAGE REPAIR (CON)	DEC 2, 21		CS0001-39	414,000.00		
	GRANT-SINKHOLE & DRAINAGE REPAIR (CON)	JAN 4, 22		CS0001-39		414,000.00	
	RUNWAY 6-24 EXTENSION-PH 4 (CON)	FEB 3, 22			444,444.00		444,444.00
VIRGINIA TECH (GA-R)	RUNWAY 12-30 EXTENSION-LAND ACQUISITION-PHASE 3	MAR 18, 21		XXXXXXXX	577,777.00		
	SPONSOR RETURN-RUNWAY 12-30 EXTENSION-LAND ACQUISITION-PHASE 3	OCT 13, 21		XXXXXXXX	577,777.00		
	LOCALIZER ACCESS ROAD (CON)	JUN 17, 21		CS0002-22	31,146.00		
	GRANT-LOCALIZER ACCESS ROAD (CON)	JUL 19, 21		CS0002-22		31,146.00	
	BOX HANGAR SITE PREPARATION (DES)	JUN 17, 21		CS0002-23	42,445.00		
	GRANT-BOX HANGAR SITE PREPARATION (DES)	JUL 19, 21		CS0002-23		42,445.00	50

VAB Package May 2022

COMMONWEALTH AVIATION FUND ALLOCATION STATUS

For the FYE June 30, 2022

as of July 7, 2021

updated 4/13/22 MS

AIRPORT TENTATIVE ALLOCATION STATUS

AIRPORT	DESCRIPTION	DATE	FAA FY	PROJECT #	DISCRETIONARY	GRANT	T.A. BALANCE
	STORMWATER POLLUTION PREVENTION PLAN UPDATE	JUN 17, 21		CS0002-24	6,530.00		
	GRANT-STORMWATER POLLUTION PREVENTION PLAN UPDATE	JUL 19, 21		CS0002-24		6,530.00	1,155,554.00
WAKEFIELD MUNICIPAL (GA-C) (NON-NPIAS)	RUNWAY LIGHTING REHABILITATION (DES)	JUN 17, 21		CS9071-18	40,000.00		
	GRANT-RUNWAY LIGHTING REHABILITATION (DES)	AUG 30, 21		CS9071-18		40,000.00	
	RUNWAY LIGHTING REHABILITATION (CON)	FEB 3, 22		CS9071-19	440,800.00		
	GRANT-RUNWAY LIGHTING REHABILITATION (CON)	MAR 8, 22		CS9071-19		440,800.00	0.00
WARRENTON-FAUQUIER (REL)							
WILLIAM M TUCK (GA-R)							
WILLIAMSBURG-JAMESTOWN (GA-C) (NON-NPIAS)	REALLOCATED FROM JAMES CITY COUNTY-ACCESS ROAD	OCT 4, 21		CS9010-39	9,132.80		
	GRANT-REALLOCATED FROM JAMES CITY COUNTY-ACCESS ROAD	NOV 8, 21		CS9010-39		9,132.80	
	T-HANGAR #2 SITE PREP (CON)	FEB 3, 22		CS9010-40	516,000.00		
	ADMIN INCREASE-T-HANGAR #2 SITE PREP (CON)	FEB 3, 22		CS9010-40	40,000.00		
	GRANT-T-HANGAR #2 SITE PREP (CON)	MAR 7, 22		CS9010-40		556,000.00	0.00
WINCHESTER REGIONAL (GA-R)	TERMINAL AREA SITE PREPARATION-PH 2 (CON)	FEB 3, 22		CS0059-33	1,064,443.00		
	ADMIN INCR-TERMINAL AREA SITE PREPARATION-PH 2 (CON)	FEB 3, 22		CS0059-33	104,000.00		
	GRANT-TERMINAL AREA SITE PREPARATION-PH 2 (CON)	MAR 7, 22		CS0059-33		1,168,443.00	
	TERMINAL BUILDING UTILITIES (CON)	FEB 3, 22		CS0059-34	98,580.00		
	GRANT-TERMINAL BUILDING UTILITIES (CON)	MAR 7, 22		CS0059-34		98,580.00	
	VAB INCREASE-TERMINAL BUILDING (DES)	FEB 3, 22		CS0059-32	39,556.72		
	AMENDMENT 1-TERMINAL BUILDING (DES)	FEB 22, 22		CS0059-32		39,556.72	0.00
OPEN T.A. BALANCE AS OF 7/7/21							3,354,995.00
TOTAL PLACED UNDER GRANT FY 2022						9,508,835.33	
TOTAL ALLOCATIONS					12,863,830.33		
TEST CHECK						0.00	

COMMONWEALTH AVIATION FUND ALLOCATION STATUS

For the FYE June 30, 2022

as of July 7, 2021

updated 4/13/22 MS

AIRPORT TENTATIVE ALLOCATION STATUS

AIRPORT	DESCRIPTION	DATE	FAA FY	PROJECT #	DISCRETIONARY	GRANT	T.A. BALANCE
---------	-------------	------	--------	-----------	---------------	-------	--------------



FEDERAL/STATE/LOCAL PROJECT



COMBINED FUND - STATE/LOCAL PROJECT



COMBINED FUND - FEDERAL/STATE/LOCAL PROJECT

CONTRACT/GRANT DOLLARS									
3/21/22 SP									
DEPARTMENT OF AVIATION FACILITIES AND EQUIPMENT PROGRAM Allocations and Expenditures For the FYE June 30, 2022									
No Funds									
Other issues									
AIRPORT ALLOCATION STATUS									
AIRPORT	DESCRIPTION / VO. PAYEE	Vo. #	DATE	W.O. #	ALLOCATION	EXPENDITURE	UNEXP. BALANCE	REVIEW	
17	EMPORIA-GREENVILLE RGNL NDB REMOVAL - DGS BILLINGS Department of General Services	6807	8/3/21	FE0013-22 FE0013-22	153.00	153.00	0.00		
18	FALWELL No Master Agreement	NEXT PROJECT		FE9073-03	0.00		0.00		
19	FARMVILLE RGNL	NEXT PROJECT		FM0015-40	0.00		0.00		
20	FRANKLIN MUNICIPAL Obst. Mitigated 7/17/19	NEXT PROJECT		FE0017-16	0.00		0.00		
21	FRONT ROYAL-WARREN CO	NEXT PROJECT		FM0019-05	0.00		0.00		
22	GORDONSVILLE MUNI.	NEXT PROJECT		FE9070-06	0.00		0.00		
23	GRUNDY MUNICIPAL	NEXT PROJECT		FE0022-07	0.00		0.00		
24	HAMPTON ROADS EXEC	NEXT PROJECT		FE0040-16	C 0.00		0.00		
25	HANOVER CO MUNI	NEXT PROJECT		FE0023-40	0.00		0.00		
26	HUMMEL FIELD (SALUDA)	CO 1 PAPI INSTALL (DESIGN)	9/20/17	FM0076-13	2,640.00		2,640.00		
		NEXT PROJECT		FM0076-17	0.00		0.00		
27	INGALL'S FIELD	NEXT PROJECT		FM0024-26	0.00		0.00		
28	LAKE ANNA	NEXT PROJECT		FM9027-12			0.00		
29	LAKE COUNTRY	NEXT PROJECT		FM9060-12	0.00		0.00		
30	LEE COUNTY	NEXT PROJECT		FM0084-06	C 0.00		0.00		
31	LEESBURG EXECUTIVE	NEXT PROJECT		FE0027-45	0.00		0.00		
32	LONESOME PINE	NEXT PROJECT		FE0060-20	0.00		0.00		
33	LOUISIANA	NEXT PROJECT		FE0078-27	0.00		0.00		

CONTRACT/GRANT DOLLARS									
3/21/22 SP	DEPARTMENT OF AVIATION FACILITIES AND EQUIPMENT PROGRAM Allocations and Expenditures For the FYE June 30, 2022								
	No Funds								
	Other issues								
AIRPORT ALLOCATION STATUS									
AIRPORT	DESCRIPTION / VO. PAYEE	Vo. #	DATE	W.O. #	ALLOCATION	EXPENDITURE	UNEXP. BALANCE	REVIEW	
51	SHENANDOAH VALLEY REG.	NEXT PROJECT		FE0049-35	0.00		0.00		
52	SMITH MOUNTAIN LAKE	NEXT PROJECT		FM9040-02	0.00		0.00		
53	STAFFORD RGNL	REPLACE LOCALIZER - EQUIP.,	1/31/22	FE0069-16	200,000.00		200,000.00		
54	SUFFOLK MUNICIPAL	NEXT PROJECT		FE0050-39	0.00		0.00		
55	TANGIER ISLAND	NEXT PROJECT		FE0051-05	0.00		0.00		
56A	TAPPAHANNOCK-ESSEX	WINDSOCK REPLACEMENT		FE0081-30	6,966.62		6,966.62		
57	TAZEWELL COUNTY	NEXT PROJECT		FE0053-25	0.00		0.00		
58	TWIN COUNTY	NEXT PROJECT		FE0020-32	0.00		0.00		
59	VIRGINIA HIGHLANDS	NEXT PROJECT		FM0001-08	0.00		0.00		
60	VIRGINIA TECH	REPLACE LOCALIZER - EQUIP., INSTALL & FLT CHK	1/29/20	FE0002-52	183,000.00				
		Virginia Tech	9/30/21	FE0002-52		4,475.00	82,725.00		
		DECREASE (reduced due to acquis of MD surplus LOC)	1/12/22	FE0002-52	(100,000.00)				
		INCREASE -			4,200.00				
61	WAKEFIELD MUNICIPAL	NEXT PROJECT		FE9071-02	0.00		0.00		
	Obstructions								
62	WARRENTON-FAUQUIER	AWOS RADIO REPAIR / REPLACEMENT		FM0068-24	0.00		0.00		
63	WILLIAMSBURG/JAMESTOWN	REPAIR BAR VASI SYSTEM	10/1/19	FM9010-11	3,740.79		3,740.79		Begin 07-10
	Monitor APT Condition								
64	WILLIAM TUCK/SOUTH BOSTON	NEXT PROJECT		FE0047-03	0.00		0.00		
65	WINCHESTER REGIONAL	NEXT PROJECT		FM0059-51	0.00		0.00		
DEPARTMENT OF AVIATION*****									
	WAREHOUSE STOCK / REPAIR ITEMS		7/1/20	FE9999-01	5,000.00		5,000.00		
	AUSTIN ELECTRICAL CONSTR. - NAV. MAINT.		7/1/19	FE9999-02	105,140.46				(Remaining bal from FY'21)
	Austin Electrical Constrction	6742	7/9/21	FE9999-02		7,680.00	(9,857.18)		
VAB Package May 2022	Austin Electrical Constrction	6776	07/20/21	FE9999-02		7,220.00			56

CONTRACT/GRANT DOLLARS									
3/21/22 SP	DEPARTMENT OF AVIATION FACILITIES AND EQUIPMENT PROGRAM Allocations and Expenditures For the FYE June 30, 2022								
	No Funds								
	Other issues								
AIRPORT ALLOCATION STATUS									
AIRPORT	DESCRIPTION / VO. PAYEE	Vo. #	DATE	W.O. #	ALLOCATION	EXPENDITURE	UNEXP. BALANCE	REVIEW	
	Austin Electrical Constrtuction	6802	7/30/2021	FE9999-02		6,375.00			
	Austin Electrical Constrtuction	6803	7/30/2021	FE9999-02		737.84			
	Austin Electrical Constrtuction	6815	8/10/21	FE9999-02		5,545.00			
	Austin Electrical Constrtuction	6854	8/25/21	FE9999-02		9,180.00			
	Austin Electrical Constrtuction	6886	9/7/21	FE9999-02		7,010.00			
	Austin Electrical Constrtuction	6887	9/7/21	FE9999-02		735.00			
	Austin Electrical Constrtuction	6915	9/16/21	FE9999-02		10,250.00			
	Austin Electrical Constrtuction	6927	9/22/21	FE9999-02		12,315.00			
	Austin Electrical Constrtuction	6941	9/30/21	FE9999-02		9,510.00			
	Austin Electrical Constrtuction	6986	10/20/21	FE9999-02		5,960.00			
	Austin Electrical Constrtuction	6987	10/20/21	FE9999-02		7,220.00			
	Austin Electrical Constrtuction	7009	10/28/21	FE9999-02		6,155.00			
	Austin Electrical Constrtuction	7053	11/18/21	FE9999-02		4,675.00			
	Austin Electrical Constrtuction	7099	12/8/21	FE9999-02		9,575.00			
	Austin Electrical Constrtuction	7100	12/8/21	FE9999-02		900.00			
	Austin Electrical Constrtuction	7101	12/8/21	FE9999-02		820.00			
	Austin Electrical Constrtuction	7102	12/8/21	FE9999-02		9,640.00			
	Austin Electrical Constrtuction	7127	12/17/21	FE9999-02		8,465.00			
	Austin Electrical Constrtuction	7128	12/17/21	FE9999-02		5,225.00			
	Austin Electrical Constrtuction	7129	12/17/21	FE9999-02		7,055.00			
	Austin Electrical Constrtuction	7169	1/12/22	FE9999-02		4,675.00			
	Austin Electrical Constrtuction	7170	1/12/22	FE9999-02		7,220.00			
	Austin Electrical Constrtuction	7171	1/12/22	FE9999-02		1,328.60			
	Austin Electrical Constrtuction	7172	1/12/22	FE9999-02		905.00			
	INCREASE (P.O. EP3419414 dated		1/12/22	FE9999-02	120,000.00				
	Austin Electrical Constrtuction	7216	1/31/22	FE9999-02		735.00			
	Austin Electrical Constrtuction	7217	1/31/22	FE9999-02		6,375.00			
	Austin Electrical Constrtuction	7298	2/28/22	FE9999-02		8,205.00			
	Austin Electrical Constrtuction	7299	2/28/22	FE9999-02		510.00			
	Austin Electrical Constrtuction	7300	2/28/22	FE9999-02		9,260.00			
	Austin Electrical Constrtuction	7301	2/28/22	FE9999-02		4,675.00			
	Austin Electrical Constrtuction	7302	2/28/22	FE9999-02		5,150.00			
	Austin Electrical Constrtuction	7335	3/16/22	FE9999-02		11,090.00			
	Austin Electrical Constrtuction	7336	3/16/22	FE9999-02		8,675.00			
	Austin Electrical Constrtuction	7337	3/16/22	FE9999-02		735.00			
	Austin Electrical Constrtuction	7338	3/16/22	FE9999-02		905.00			
	Austin Electrical Constrtuction	7339	3/16/22	FE9999-02		820.00			
	Austin Electrical Constrtuction	7346	3/18/22	FE9999-02		5,575.00			
	Austin Electrical Constrtuction	7423	4/20/22	FE9999-02		1,722.91			
	Austin Electrical Constrtuction	7424	4/20/22	FE9999-02		4,675.00			
	Austin Electrical Constrtuction	7425	4/20/22	FE9999-02		7,220.00			
	Austin Electrical Constrtuction	7439	4/27/22	FE9999-02		143.29			
	Austin Electrical Constrtuction	7440	4/27/22	FE9999-02		1,330.00			
	Austin Electrical Constrtuction	7441	4/27/22	FE9999-02		820.00			
	DEAN KENNEDY - ILS TECH. SERV. - NAV. MAINT.		7/1/19	FE9999-03	59,055.00				(Remaining bal from FY'21)
	ILS Technical Service	6743	7/9/21	FE9999-03		6,060.00	10,272.50		
	ILS Technical Service	6812	08/04/21	FE9999-03		3,760.00			
	ILS Technical Service	6885	9/7/21	FE9999-03		8,900.00			
	ILS Technical Service	6955	10/7/21	FE9999-03		3,675.00			
	ILS Technical Service	7023	11/10/21	FE9999-03		5,925.00			
	ILS Technical Service	7111	12/13/21	FE9999-03		4,175.00			
	ILS Technical Service	7218	1/31/22	FE9999-03		4,600.00			
	ILS Technical Service	7324	3/10/22	FE9999-03		7,885.00			
	ILS Technical Service	7386	4/7/22	FE9999-03		3,802.50			
	SURVEY EQUIPMENT (cc. 541, ac 1311)		11/6/20	FE9999-55	540.00				
	SOUTHERN AVIONICS - NDB PARTS			FE9999-57	0.00		540.00		
VAB Package May 2022							0.00		57

CONTRACT/GRANT DOLLARS									
3/21/22 SP	DEPARTMENT OF AVIATION FACILITIES AND EQUIPMENT PROGRAM Allocations and Expenditures For the FYE June 30, 2022								
	No Funds								
	Other issues								
AIRPORT ALLOCATION STATUS									
AIRPORT	DESCRIPTION / VO. PAYEE	Vo. #	DATE	W.O. #	ALLOCATION	EXPENDITURE	UNEXP. BALANCE	REVIEW	
	THALES - (AIRSYS ATM) - PARTS		7/1/21	FE9999-58	4,194.00				(Remaining bal from FY'21)
	THALES - (AIRSYS ATM) - PARTS		2/17/22	FE9999-58	(4,194.00)				(Reclaimed unused carryov
	MARK 1F LOC PARTS		8/24/21	FE9999-58	7,004.00		0.00		
	THALES - 415DME PART REPAIR		2/16/22	FE9999-58	3,012.00				
	Thales	7361	3/23/22	FE9999-58		3,012.00			
	Thales	7438	4/27/22	FE9999-58		7,004.00			
	SELEX (OLD ARLENIA MARCONI SYSTEMS (ASII)) - PARTS		7/1/21	FE9999-59	5,000.00		5,000.00		
	UPS/FEDEX SHIPPING			FE9999-60	500.00		500.00		
	cc541 ac1212								
	AAR COOPER (MIC'S/Antenna's)			FE9999-62	0.00		0.00		
	PARK AIR INC. - AWOS TRANSCEIVER			FE9999-63	0.00		0.00		
	INTERNATIONAL CRYSTAL MANUF			FE9999-65	0.00		0.00		
	FAA DEPOT			FE9999-66	0.00		0.00		
	MCG SURGE PROTECTION			FE9999-67	0.00		0.00		
	AWOS DATA NETWORKING		7/1/21	FE9999-69	8,288.05				(Remaining bal from FY'22)
	RSI NETLLC	6804	8/2/21	FE9999-69		3,538.04	8,683.54		
	RSI NETLLC	6988	10/21/21	FE9999-69		3,538.25			
	INCREASE (P.O. EP33349737)		7/8/21	FE9999-69	14,400.00				
	RSI NETLLC	7198	1/20/22	FE9999-69		3,463.85			
	RSI NETLLC	7387	4/7/22	FE9999-69		3,464.37			
	UNICOM RADIOS		7/1/20	FE9999-70	0.00		0.00		
	NAVAID BUILDING REPAIRS - LKU A/C		7/1/21	FE9999-71	0.00		0.00		
	BIRD ELECTRONICS			FE9999-74	0.00		0.00		
	NAVAID COMPUTER SERVICE - VITA			FE9999-75	0.00		0.00		
	AUTODESK AUTOCAD SUBSCRIPTION		1/19/22	FE9999-76	3,200.00				
	SHI International Corp	7219	1/31/22	FE9999-76		3,192.88	7.12		
	B R COMMUNICATIONS (UNICOMS)			FE9999-77	0.00		0.00		
	NAVAID BUILDINGS - TRANSPORT			FE9999-83	0.00		0.00		
	PUBLICATION SUBSCRIPTIONS		7/1/21	FE9999-84	57.86				
	INCREASE (New P.O. & price increase)		8/23/21	FE9999-84	300.00		357.86		(Remaining bal from FY'22)

Balance		Test		DEPARTMENT OF AVIATION																	
98,649.61		0.00		MAINTENANCE PROGRAM																	
		No Funds		Allocations and Expenditures																	
		Other issues		For the FYE June 30, 2022																	
				APPROPRIATION JULY, 2021				750,000.00													
05/03/22 ANJ				LESS PRIOR YEAR OVERCOMMITMENT				0.00													
				PLUS: PRIOR YEAR COMMITMENTS				XXXXXX													
				TOTAL APPROPRIATION FY 2022				750,000.00													
** \$75,000 MAX TO SPONSOR PER YEAR																					
												AIRPORT ALLOCATION STATUS									
AIRPORT	Expiration	DESCRIPTION / VO. PAYEE	VO. NO.	DATE	PROJ. #		JULY-SEPT	OCT-DEC	JAN-MAR	APR-JUN	EXPENDITURE	UNEXP. BALANCE									
ACCOMACK (T 80%, F 67%) 54,049.40	9/1/21	FY21 AWOS INSP & REPAIR Accomack County	6878	7/1/20 8/31/21	MT0033-17 MT0033-17	C	1,220.00				1,140.00	80.00									
	11/30/21	REPLACE TERMINAL BUILDING ENTRANCE DOORS Accomack County	7028	5/27/21 11/10/21	MT0033-24 MT0033-24	C	6,960.00				6,960.00	0.00									
	9/1/21	AWOS EVAL - TEMP SENSOR FINAL DECREASE - SP Accomack County	6868	5/27/21 8/30/21 8/31/21	MT0033-25 MT0033-25 MT0033-25	C	1,002.25 (760.00)				242.25	0.00									
	11/1/21	REPLACE PCA VOICE SPARE AWOS FINAL DECREASE - SP Accomack County	700	5/27/21 10/26/21 10/28/21	MT0033-26 MT0033-26 MT0033-26	C	4,062.69 (2,862.55)				1,200.14	(0.00)									
	6/1/22	FY22 AWOS INSP & REPAIR Accomack County	7012	7/1/21 10/28/21	MT0033-27 MT0033-27		3,500.00				1,140.00	2,360.00									
	9/1/21	REPLACE AWOS TEMP PROBE Accomack County (Note - replaced with a recalibrated probe) VC 04-18-22	6873	7/14/21 8/31/21	MT0033-28 MT0033-28	C	1,960.14				1,960.14	0.00									
	4/1/22	SECURITY GATE REPAIR FINAL INCREASE - SP Accomack County	7289	1/27/22 2/23/22 2/23/22	MT0033-29 MT0033-29 MT0033-29	C			1,440.00 100.00			1,540.00	0.00								
	6/1/22	ROTATING BEACON LIGHT REPLACEMENT Accomack	7442	3/24/22 4/27/22	MT0033-30 MT0033-30	C			1,542.40			1,542.40	0.00								
	6/1/22	AWOS TEMPERATURE PROBE REPLACEMENT		4/18/22	MT0033-31					2,785.67		2,785.67									
	BLACKSTONE (T: ?, F: 33%) 71,795.98	12/15/21	AWOS EVALUATION & REPAIR INCREASE FOR ADDTL REPAIR FINAL Town of Blackstone	7252	9/9/21 11/4/21 1/11/22 2/8/22	MT0008-13 MT0008-13 MT0008-13 MT0008-13	C	1,273.00	1,931.02			3,204.02	0.00								
BLUE RIDGE (T 80%, F 80%) 65,963.75	9/1/21	FY21 AWOS INSP & REPAIR Blue Ridge Airport Authority	6727	7/1/20 7/1/21	MT0032-60 MT0032-60	C	3,500.00				3,420.00	80.00									
	6/1/22	FY22 AWOS INSP & REPAIR		7/1/21	MT0032-64		3,500.00					3,500.00									
	12/1/21	TAXIWAY LIGHTING OUTAGE Blue Ridge Airport Authority	7065	7/20/21 11/29/21	MT0032-65 MT0032-65	C	844.00				844.00	0.00									
	10/1/21	AWOS OUTAGE Blue Ridge Airport Authority	6935	8/12/21 9/30/21	MT0032-66 MT0032-66	C	1,192.25				1,192.25	0.00									
BRIDGEWATER Identified 9/15/16 70,360.00	9/1/21	FY21 AWOS INSP & REPAIR Dynamic Aviation Group Inc CLOSE - ANJ	6770	7/1/20 7/20/21 3/24/22	MT9072-17 MT9072-17 MT9072-17	C	1,220.00 (80.00)				1,140.00	0.00									
	11/1/22	FY22 AWOS INSP & REPAIR Dynamic Aviation Group Inc	7027	7/1/21 11/10/21	MT9072-19 MT9072-19		3,500.00				1,140.00	2,360.00									
BROOKNEAL (T: ?, F: 67%) 64,000.52	11/1/21	FY21 AWOS INSP & REPAIR FINAL - DECREASE Brookneal Campbell Airport Authority	6906	7/1/20 9/8/21 9/13/21	MT0062-34 MT0062-34 MT0062-34	C	3,500.00 (1,315.00)				2,185.00	0.00									
	11/1/21	WEEDKILL APPLICATION FINAL		5/27/21 9/10/21	MT0062-35 MT0062-35	C	3,024.00					60	0.00								
	VAB Package May 2022																				

AIRPORT	Expiration	DESCRIPTION / VO. PAYEE	VO. NO.	DATE	PROJ. #	AIRPORT ALLOCATION STATUS				EXPENDITURE	UNEXP. BALANCE
						JULY-SEPT	OCT-DEC	JAN-MAR	APR-JUN		
		Brookneal Campbell Airport Authority	6905	9/13/21	MT0062-35					3,024.00	
	6/1/22	FY22 AWOS INSP & REPAIR		7/1/21	MT0062-36	3,500.00					3,500.00
	6/1/22	AWOS OUTAGE EVALUATION INCREASE FOR REPAIR		10/22/21	MT0062-37		1,192.25				0.00
		FINAL - DECREASE		11/18/21	MT0062-37		1,098.23				
		Brookneal Campbell Airport Authority	7348	3/16/22	MT0062-37		(760.00)			1,530.48	
				3/21/22	MT0062-37						
BRUNSWICK COUNTY 72,435.00	6/1/22	FY22 AWOS INSP & REPAIR		7/1/21	MT9012-54	3,500.00					
		Brunswick County	7166	1/12/22	MT9012-54					1,710.00	855.00
		FINAL - DECREASE		5/3/22	MT9012-54	(935.00)					
CHARLOTTESVILLE 75,000.00		NEXT			MT0004-56	0.00					0.00
CHASE CITY 70,360.00	9/1/21	FY21 AWOS INSP & REPAIR		7/1/20	MT0005-19	1,220.00					0.00
		FINAL - DECREASE		7/21/21	MT0005-19	(80.00)					
		Town of Chase City	6789	7/27/21	MT0005-19					1,140.00	
	6/1/22	FY22 AWOS INSP & REPAIR		7/1/21	MT0005-20	3,500.00					
		Town of Chase City	7120	12/15/21	MT0005-20					1,140.00	2,360.00
		NEXT PROJECT			MT0005-21	0.00					0.00
CHESAPEAKE(T: 80, F: 50) 65,656.48	6/1/22	FY22 AWOS INSP & REPAIR		7/1/21	MT0006-82	3,500.00					
		Chesapeake Airport Authority	7275	2/16/22	MT0006-82					1,140.00	2,360.00
	3/1/22	REPLACEMENT AIRFIELD LAMPS		10/28/21	MT0006-83		1,374.24				0.00
		FINAL - INCREASE (ALLOWABLE 10%)		2/15/22	MT0006-83		102.08				
		Chesapeake Airport Authority	7282	2/23/22	MT0006-83					1,476.32	
	3/1/22	SEGMENTED CIRCLE REPAINTING		12/9/21	MT0006-84		406.10				0.00
		FINAL - DECREASE		2/12/22	MT0006-84		(4.98)				
		Chesapeake Airport Authority	7283	2/23/22	MT0006-84					401.12	
	6/1/22	VEGETATION MGMT & PREVENTION		3/10/22	MT0006-85			3,966.08			3,966.08
		AWOS TROUBLESHOOT (95%) CLOSED AT AIRPORT REQUEST		3/15/22	MT0006-86			1,273.00			0.00
				5/2/22	MT0006-86			(1,273.00)			
CREWE (T: 80, F: 67%) 71,500.00	6/1/22	FY22 AWOS INSP & REPAIR		7/1/21	MT9065-30	3,500.00					
		Town of Crewe	7075	12/1/21	MT9065-30					1,140.00	2,360.00
CULPEPER (T: ?, F: 67%) 65,527.80	9/1/21	FY21 AWOS INSP & REPAIR		7/1/20	MT0010-44	1,220.00					0.00
		County of Culpeper	6756	7/13/21	MT0010-44					1,140.00	
		CLOSE - ANJ		3/24/22	MT0010-44	(80.00)					
	9/1/21	2021 WEEDKILL APPLICATION		5/27/21	MT0010-46	3,289.00					0.00
		FINAL DECREASE - SP		8/17/21	MT0010-46	(481.80)					
		County Of Culpeper	6837	8/17/21	MT0010-46					2,807.20	
	6/1/22	FY22 AWOS INSP & REPAIR		7/1/21	MT0010-47	3,500.00					
		County of Culpeper	7151	1/10/22	MT0010-47					2,280.00	1,220.00
	6/30/22	SNOW PUSHER JOHN DEERE TRACTOR		1/20/22	MT0010-48			2,025.00			2,025.00
DANVILLE (T 28.1% PARK 25%) 75,000.00		NEXT PROJECT			MT0011-48	0.00					0.00
DEPARTMENT OF MILITAF	9/1/21	FY21 AWOS INSP & REPAIR		7/1/20	MT0DMA-07	3,500.00					0.00
		CLOSE - ANJ		9/14/21	MT0DMA-07	(3,500.00)					
	6/1/22	FY22 AWOS INSP & REPAIR		7/1/21	MT0DMA-08	3,500.00					
		Town of Blackstone	7251	2/8/22	MT0DMA-08					1,140.00	2,360.00
		NEXT PROJECT			MT0DMA-09	0.00					0.00
DINWIDDIE (T: 72%, F: 7%) VAB Package May 2022	6/1/22	FY22 AWOS INSP & REPAIR		7/1/21	MT0039-33	3,500.00					61

AIRPORT	Expiration	DESCRIPTION / VO. PAYEE	VO. NO.	DATE	PROJ. #	AIRPORT ALLOCATION STATUS				EXPENDITURE	UNEXP. BALANCE
						JULY-SEPT	OCT-DEC	JAN-MAR	APR-JUN		
69,901.08		Dinwiddie Airport and Industrial Authority	7068	11/29/21	MT0039-33					1,140.00	2,360.00
	11/1/21	REIL COMPLETION Dinwiddie Airport and Industrial Authority	7071	7/29/21 11/30/21	MT0039-34 MT0039-34	C	1,598.92			1,598.92	0.00
	7/1/22	AWOS WIND SENSOR REPLACEMENT		4/7/22	MT0039-35				1,244.50		1,244.50
	7/1/22	REPLACE WIND BEARING KIT ON AWOS		4/20/22	MT0039-36				1,438.24		1,438.24
EAGLE'S NEST 71,500.00	6/1/22	FY22 AWOS INSP & REPAIR Aero Drive Farm, Inc	6761	7/1/21 7/14/21	MT9089-28 MT9089-28		3,500.00			1,140.00	2,360.00
		NEXT PROJECT			MT9089-29		0.00				0.00
EMPORIA-GREENSVILLE (59,220.18	11/1/21	FY21 AWOS INSP & REPAIR CLOSED AT AIRPORT REQUEST		7/1/20 1/11/22	MT0013-79 MT0013-79	W	1,220.00 (1,220.00)				0.00
	11/1/21	OBSTRUCTION IDENTIFICATION FINAL - INCREASE (ALLOWABLE 10%) Emporia Greenville Airportr	6992	5/27/21 10/19/21 10/25/21	MT0013-80 MT0013-80 MT0013-80	C	3,360.00 336.00			3,696.00	0.00
	3/1/22	EVALUATION AWOS OUTAGE (95%) CLOSED AT AIRPORT REQUEST		5/27/21 2/23/22	MT0013-81 MT0013-81	W	1,273.00 (1,273.00)				0.00
	6/1/22	FY22 AWOS INSP & REPAIR Emporia Greenville Airport Commission Emporia Greenville Airport Commission	7049 7413	7/1/21 11/18/21 4/20/22	MT0013-82 MT0013-82 MT0013-82		3,500.00			1,140.00 1,140.00	1,220.00
	12/1/21	ROTATING BEACON TROUBLESHOOT INCREASE ALLOCATION PER RCVD QUOTE ON 6/30/21 - ANJ FINAL Emporia Greenville Airport Commission	7030	7/14/21 11/4/21 11/4/21 11/10/21	MT0013-83 MT0013-83 MT0013-83 MT0013-83	C	928.00 400.00			1,328.00	0.00
	3/1/22	AWOS EVALUATION FINAL Emporia Greenville Airport Commission	7293	1/20/22 2/25/22 2/28/22	MT0013-84 MT0013-84 MT0013-84	C		1,083.00		1,083.00	0.00
	6/1/22	AWOS UHF RADIO REPLACEMENT		2/10/22	MT0013-85			6,172.82			6,172.82
FALWELL 75,000.00		NEXT PROJECT			MT9073-17		0.00				0.00
Missing State Funding Annual Report Funding Report - N/A - no funds rec'd -VC No Master Agreement											
FARMVILLE (T: 80, F: 33%) 61,402.79	9/1/21	FY21 AWOS INSP & REPAIR FINAL - DECREASE Town of Farmville	6790	7/1/20 7/21/21 7/27/21	MT0015-10 MT0015-10 MT0015-10	C	1,220.00 (80.00)			1,140.00	0.00
	9/1/21	AWOS TROUBLESHOOT FINAL - DECREASE Town of Farmville	6791	4/1/21 7/21/21 7/27/21	MT0015-13 MT0015-13 MT0015-13	C	1,140.00 (57.00)			1,083.00	0.00
	6/1/22	FY22 AWOS INSP & REPAIR Town of Farmville	7076	7/1/21 12/1/21	MT0015-14 MT0015-14		3,500.00			1,140.00	2,360.00
	12/15/21	AWOS DIAL-UP EVALUATION FINAL Town of Farmville	7083	7/14/21 11/30/21 12/1/21	MT0015-15 MT0015-15 MT0015-15	C	2,384.50			2,384.50	0.00
	3/1/22	AWOS OUTAGE EVALUATION FINAL - DECREASE Town Of Farmville	7281	10/28/21 2/22/22 2/23/22	MT0015-16 MT0015-16 MT0015-16	C		1,273.00 (950.00)		323.00	0.00
	6/1/22	AWOS THUNDERSTORM SENSOR CABLE REPAIR CLOSED AT AIRPORT REQUEST		12/9/21 2/22/22	MT0015-17 MT0015-17	W		1,083.00 (1,083.00)			0.00
	6/1/22	REIL DC POWER SUPPLY		3/3/22	MT0015-18			1,201.82			1,201.82
	6/1/22	REIL LED & MOTHERBOARDS INCREASE FOR ADDTL LED BOARDS		3/17/22 4/1/22	MT0015-19 MT0015-19			1,293.69 1,711.20			62 3,004.89
VAB Package May 2022											

AIRPORT	Expiration	DESCRIPTION / VO. PAYEE	VO. NO.	DATE	PROJ. #	AIRPORT ALLOCATION STATUS				EXPENDITURE	UNEXP. BALANCE
						JULY-SEPT	OCT-DEC	JAN-MAR	APR-JUN		
		WEED KILLER (100%)		3/17/22	MT0015-20			960.00			960.00
FRANKLIN (T: 80, F: 67%) Obst. Mitigated 7/17/19 70,417.00	11/1/22	FY22 AWOS INSP & REPAIR		7/1/21	MT0017-74	3,500.00					3,500.00
	6/15/22	AWOS THUNDERSTORM SENSOR REPAIR		4/7/22	MT0017-75				1,083.00		1,083.00
FRONT ROYAL (T: 78%, F: 68,744.00)	6/1/22	FY22 AWOS INSP & REPAIR		7/1/21	MT0019-59	3,500.00					
		County of Warren	7077	12/1/21	MT0019-59					1,140.00	2,360.00
	3/1/22	AWOS WIND SENSOR REPLACEMENT INCREASE FOR ADDTL REPAIRS FINAL - DECREASE County of Warren	7108	10/28/21 11/12/21 12/8/21 12/13/21	MT0019-60 MT0019-60 MT0019-60 MT0019-60			1,678.86 1,837.14 (760.00)		2,756.00	0.00
		AWOS TEMP/DEW POINT SENSOR REPLACEMENT		4/22/22	MT0019-61				1,913.68		1,913.68
GORDONSVILLE 71,500.00	6/1/22	FY22 AWOS INSP & REPAIR		7/1/21	MT9070-33	3,500.00					
		Town of Gordonsville	6859	8/25/21	MT9070-33					1,140.00	1,220.00
		Town of Gordonsville	7121	12/15/21	MT9070-33					1,140.00	
	3/15/22	AWOS OBSTRUCTION LIGHT REPAIR FINAL - DECREASE Town of Gordonsville	7315	12/9/21 3/3/22 3/9/22	MT9070-34 MT9070-34 MT9070-34			1,174.20 (760.00)		414.20	0.00
	3/15/22	ROTATING BEACON BALLAST REPAIR FINAL Town of Gordonsville	7316	12/9/21 3/3/22 3/9/22	MT9070-35 MT9070-35 MT9070-35			1,987.47		1,987.47	0.00
		AWOS OUTAGE EVALUATION		4/19/22	MT9070-36				1,273.00		1,273.00
		ROTATING BEACON REPAINTING		4/22/22	MT9070-37				7,249.60		7,249.60
GRUNDY 75,000.00		NEXT PROJECT			MT0022-17	0.00					0.00
HAMPTON ROADS 44,409.63	11/1/21	RWY 28 REILS REPAIR Hampton Roads Airport	6869	3/18/21 8/31/21	MT0040-76 MT0040-76	5,892.00				4,619.30	1,272.70
	9/1/21	2021 WEEDKILL APPLICATION HAMPTON ROADS AIRPORT	6760	5/27/21 7/13/21	MT0040-77 MT0040-77	3,480.00				3,480.00	0.00
	11/1/21	RWY 28 REILS ADDITIONAL MOBILIZATION Hampton Roads Airport	6984	8/26/21 10/20/21	MT0040-78 MT0040-78	1,700.95				1,700.95	0.00
	4/1/22	RWY 28 REILS REPAIR SLAVE UNIT Hampton Roads Airport	7331	12/2/21 3/16/22	MT0040-79 MT0040-79			2,297.55		2,297.55	0.00
	4/1/22	FOD SWEEP NET REPLACEMENT Hampton Roads Airport	7212	1/6/22 1/26/22	MT0040-80 MT0040-80			1,547.50		1,547.50	0.00
	6/1/22	12' RUBBER EDGE SNOW PUSHER		3/4/22	MT0040-81				3,814.12		3,814.12
	6/1/22	WEED CONTROL Hampton Roads Airport	7388	3/10/22 4/11/22	MT0040-82 MT0040-82			5,869.25		5,869.25	0.00
	9/30/22	ZERO TURN MOWER REPLACEMENT Hampton Roads Airport	7443	3/24/22 4/27/22	MT0040-83 MT0040-83			5,989.00		5,989.00	0.00
	7/1/22	RWY 28 REILS SLAVE UNIT #2		4/14/22	MT0040-84				1,472.80		1,472.80
HANOVER (T: ?, F: 50%) 68,023.39	5/31/22	ZERO TURN MOWER - KUBOTA Hanover County Community Services	7202	9/3/21 1/24/22	MT0023-60 MT0023-60	6,976.61				6,976.61	0.00
VAB Package May 2022	7/1/22	VEGETATION MANAGEMENT 2022		4/4/22	MT0023-61				2,360.80		63 2,360.80

AIRPORT	Expiration	DESCRIPTION / VO. PAYEE	VO. NO.	DATE	PROJ. #	AIRPORT ALLOCATION STATUS				EXPENDITURE	UNEXP. BALANCE			
						JULY-SEPT	OCT-DEC	JAN-MAR	APR-JUN					
HUMMEL FIELD (T 65%, F € 66,381.62)	9/1/21	FY21 AWOS INSP & REPAIR Middlesex County	6838	7/1/20 8/17/21	MT0076-69 MT0076-69	C	1,220.00					1,140.00	80.00	
	9/1/21	2021 WEEDKILL APPLICATION Middlesex County	6839	5/27/21 8/17/21	MT0076-71 MT0076-71	C	780.00					780.00	0.00	
	6/1/22	FY22 AWOS INSP & REPAIR Middlesex County	7319	7/1/21 3/9/22	MT0076-72 MT0076-72		3,500.00					2,280.00	1,220.00	
	6/1/22	AWOS BATTERY BACKUP Middlesex County	7363	3/10/22 3/23/22	MT0076-73 MT0076-73	C			1,085.38			1,085.38	0.00	
	6/1/22	AWOS TEMP AND DEW POINT SENSOR Middlesex County	7362	3/10/22 3/23/22	MT0076-74 MT0076-74	C			2,033.00			1,273.00	760.00	
	6/1/22	AWOS TEMP AND DEW POINT SENSOR EVAL		3/24/22	MT0076-75				1,002.25					1,002.25
	11/1/20	FY20 AWOS INSP & REPAIR		7/1/19	MT0024-96	C	2,090.00							2,090.00
INGALLS FIELD (T 80%, F € 66,925.94)	12/31/21	FY21 AWOS INSP & REPAIR Bath County Airport Authority	7087	7/1/20 12/7/21	MT0024-01 MT0024-01	C	1,211.06					1,140.00	71.06	
	6/1/22	FY22 AWOS INSP & REPAIR		7/1/21	MT0024-03		3,500.00						3,500.00	
	11/1/21	AWOS OUTAGE Bath County Airport Commission	6959	9/9/21 10/12/21	MT0024-04 MT0024-04	C	1,273.00					1,273.00	0.00	
	6/1/22	EVAL AWOS OUTAGE		4/12/22	MT0024-05					1,273.00			1,273.00	
	6/1/22	FY22 AWOS INSP & REPAIR Miles High Charters LLC Miles High Charters LLC	6783 7321	7/26/21 3/9/22	MT9027-31 MT9027-31 MT9027-31		3,500.00					1,140.00 1,140.00	1,220.00	
LAKE ANNA 67,541.34	3/15/22	AWOS BATTERY AND VHF ANTENNA REPLACEMENT FINAL-DECREASE Miles High Charters LLC	7317	12/17/21 3/3/22 3/9/22	MT9027-32 MT9027-32 MT9027-32	C		2,036.94 (760.00)				1,276.94	0.00	
	6/1/22	AWOS TROUBLESHOOT FINAL - DECREASE Miles High Charters LLC	7318	1/13/22 3/3/22 3/9/22	MT9027-33 MT9027-33 MT9027-33	C			1,083.00 (760.00)			323.00	0.00	
	6/1/22	AWOS CPU CARD REPLACEMENT FINAL - DECREASE Miles High Charters LLC	7416	3/3/22 4/12/22 4/20/22	MT9027-34 MT9027-34 MT9027-34	C			3,118.72 (760.00)			2,358.72	0.00	
		AWOS TEMP SENSOR TROUBLESHOOT FINAL		4/19/22 5/3/22	MT9027-35 MT9027-35	C				1,273.00			1,273.00	
	9/1/21	FY21 AWOS INSP & REPAIR Lake County Airport Commission CLOSED - ANJ	6825	7/1/20 8/10/21 11/8/21	MT9060-57 MT9060-57 MT9060-57	C	3,500.00					3,420.00	0.00	
	11/1/21	WEED CONTROL FINAL Lake County Airport Commission	6903	5/27/21 9/8/21 9/13/21	MT9060-59 MT9060-59 MT9060-59	C	2,755.20					2,755.20	0.00	
LAKE COUNTRY 63,159.17	6/1/22	FY22 AWOS INSP & REPAIR		7/1/21	MT9060-60		3,500.00						3,500.00	
		WEED CONTROL		3/10/22	MT9060-61				2,165.63				2,165.63	
	6/1/22	FY22 AWOS INSP & REPAIR		7/1/21	MT0084-33		3,500.00						3,500.00	
LEE COUNTY 65,080.80	12/1/21	AWOS TEMPERATURE PROBE REPLACEMENT FINAL Lee County	7031	8/12/21 11/3/21 11/10/21	MT0084-34 MT0084-34 MT0084-34	C	2,717.95					2,717.95	0.00	
	12/1/21	RWY 25 PAPI TROUBLESHOOT FINAL Lee County	7032	8/17/21 11/3/21 11/10/21	MT0084-35 MT0084-35 MT0084-35	C	800.00					800.00	64	
	VAB Package May 2022												0.00	

AIRPORT	Expiration	DESCRIPTION / VO. PAYEE	VO. NO.	DATE	PROJ. #	AIRPORT ALLOCATION STATUS				EXPENDITURE	UNEXP. BALANCE		
						JULY-SEPT	OCT-DEC	JAN-MAR	APR-JUN				
	12/1/21	ROTATING BEACON TROUBLESHOOT FINAL Lee County	7033	9/23/21 11/3/21 11/10/21	MT0084-36 MT0084-36 MT0084-36	C	1,120.00					1,120.00	0.00
	6/1/22	AWOS COMM. LINK REPAIR		2/3/22	MT0084-37				1,781.25				1,781.25
LEESBURG 68,610.44	9/1/21	HERBICIDE TREATMENT - APRONS & FENCE Town of Leesburg	6850	5/27/21 8/24/21	MT0027-08 MT0027-08	C	2,240.00					2,240.00	0.00
	6/1/22	FY22 AWOS INSP & REPAIR Town of Leesburg	7067	7/1/21 11/29/21	MT0027-09 MT0027-09		3,500.00					1,140.00	2,360.00
	11/1/21	AWOS TEMP SENSOR Town Of Leesburg	6956	8/26/21 10/12/21	MT0027-10 MT0027-10	C	649.56					649.56	0.00
LONESOME PINE (T 81% F) 67,986.40	6/1/22	FY22 AWOS INSP & REPAIR Cumberland Airport Commission	7250	7/1/21 2/8/22	MT0060-51 MT0060-51		3,500.00					1,900.00	1,600.00
	11/1/21	PLUMBING REPAIRS (80%) FINAL Cumberland Airport Commission	6904	7/29/21 9/8/21 9/13/21	MT0060-52 MT0060-52 MT0060-52	C	1,591.20					1,591.20	0.00
	3/1/22	PCL TROUBLESHOOT FINAL Cumberlands Airport Commission	7044	11/4/21 11/16/21 11/17/21	MT0060-53 MT0060-53 MT0060-53	C		480.00				480.00	0.00
	3/1/22	ODAL EVALUTATION FINAL Cumberlands Airport Commission	7138	11/12/21 12/17/21 1/4/22	MT0060-54 MT0060-54 MT0060-54	C		839.20				839.20	0.00
	6/1/22	PCL REPAIR FINAL Cumberlands Airport Commission	7225	1/6/22 2/1/22 2/2/22	MT0060-55 MT0060-55 MT0060-55	C			603.20			603.20	0.00
LOUISA 69,957.00	9/1/21	FY21 AWOS INSP & REPAIR		7/1/20	MT0078-79	C	1,220.00						1,220.00
	6/1/22	FY22 AWOS INSP & REPAIR Louisa County Louisa County	6960 7253	7/1/21 10/12/21 2/8/22	MT0078-82 MT0078-82 MT0078-82		3,500.00					1,140.00 1,140.00	1,220.00
	11/1/21	AWOS EVAL AND REPAIR WEATHER SENSOR FINAL DECREASE - SP Industrial Development Authority Of Louisa County	7014	9/16/21 10/26/21 10/28/21	MT0078-83 MT0078-83 MT0078-83	C	1,083.00 (760.00)					323.00	0.00
LUNENBURG 51,496.38 <i>Obstructions identified 8/11/21 Sponsor notified 8/26/21 Obstr. Mitigated by lic recl. 2/11/2022</i>	9/1/21	FY21 AWOS INSP & REPAIR FINAL - DECREASE County of Lunenburg Board Of Supervisors	6792	7/1/20 7/21/21 7/27/21	MT0025-52 MT0025-52 MT0025-52	C	3,500.00 (1,742.50)					1,757.50	0.00
	6/1/22	FY22 AWOS INSP & REPAIR		7/1/21	MT0025-54		3,500.00						3,500.00
	12/15/21	WINDSOCK REPLACEMENT FINAL - DECREASE County Of Lunenburg Board of Supervisors	7045	7/29/21 11/16/21 11/17/21	MT0025-55 MT0025-55 MT0025-55	C	143.28 (11.14)					132.14	0.00
	12/15/21	AWOS TEMP/DEW POINT SENSOR REPAIR FINAL County Of Lunenburg Board of Supervisors	7043	8/12/21 11/9/21 11/17/21	MT0025-56 MT0025-56 MT0025-56	C	1,667.25					1,667.25	0.00
	12/15/21	FUEL FARM FLOW METER REPAIR (67%) INCREASE FOR REPAIRS FINAL - DECREASE County of Lunenburg Board Of Supervisors	7046	8/12/21 9/23/21 11/9/21 11/17/21	MT0025-57 MT0025-57 MT0025-57 MT0025-57	C	2,465.60 3,553.62 (1,872.49)					4,146.73	0.00
	11/1/22	OBSTRUCTION REMOVAL 2022		1/27/22	MT0025-58				10,400.00				10,400.00
	11/1/22	AWOS WIND SENSOR REPAIR		2/18/22	MT0025-59				1,900.00				1,900.00
LURAY 56,749.05	VAB Package May 2022	FY22 AWOS INSP & REPAIR		7/1/21	MT0067-45		3,500.00						65 3,500.00

AIRPORT	Expiration	DESCRIPTION / VO. PAYEE	VO. NO.	DATE	PROJ. #	AIRPORT ALLOCATION STATUS				EXPENDITURE	UNEXP. BALANCE		
						JULY-SEPT	OCT-DEC	JAN-MAR	APR-JUN				
	12/1/21	VENTRAC 4500Y MOWER FINAL - DECREASE Luray Page County Airport Authority	7048	7/27/21 11/9/21 11/18/21	MT0067-46 MT0067-46 MT0067-46	C	14,757.20 (6.25)					14,750.95	0.00
LYNCHBURG REGIONAL 75,000.00		NEXT PROJECT			MT0029-46		0.00						0.00
MANASSAS REGIONAL (F) 23,269.00	9/1/21	TERMINAL BUILDING ROOF REPLACEMENT (Construction) 69.5% FINAL City of Manassas	6793	7/28/20 7/21/21 7/27/21	MT0030-69 MT0030-69 MT0030-69	C	49,067.00					49,067.00	0.00
		TAXIWAY "B" RESTRIPIING		4/7/22	MT0030-70					2,664.00			2,664.00
MECKLENBURG (T = 80%) 58,904.30	9/1/21	FUEL FARM PULSER (67%) INCREASE FOR ADDTL REPAIRS FINAL - DECREASE Mecklenburg Brunswick Regional Airport Commission	6874	5/27/21 7/14/21 8/25/21 8/31/21	MT0070-81 MT0070-81 MT0070-81 MT0070-81	C	830.13 2,476.99 (830.13)					2,476.99	0.00
	6/1/22	FY22 AWOS INSP & REPAIR Mecklenburg Brunswick Regional Airport Commission	7167	7/1/21 1/12/22	MT0070-84 MT0070-84		3,500.00					1,900.00	1,600.00
	12/15/21	SECURITY GATE KEYPAD REPLACEMENT INCREASE FOR ADDTL REPAIRS FINAL - DECREASE Mecklenburg Brunswick Regional Airport Commission	7080	9/16/21 10/7/21 11/30/21 12/1/21	MT0070-85 MT0070-85 MT0070-85 MT0070-85	C	981.18 526.62 (19.02)					1,488.78	0.00
	12/15/21	AIRFIELD LIGHTING REPAIRS FINAL Mecklenburg Brunswick Regional Airport Commission	7081	9/16/21 11/30/21 12/1/21	MT0070-86 MT0070-86 MT0070-86	C	3,422.40					3,422.40	0.00
	12/15/21	AWOS WIND SENSOR BEARING REPLACEMENT (95%) FINAL Mecklenburg Brunswick Regional Airport Commission	7082	9/23/21 11/30/21 12/1/21	MT0070-87 MT0070-87 MT0070-87	C	653.13					653.13	0.00
	3/1/22	AIRFIELD LIGHTING REPAIRS FINAL Mecklenburg Brunswick Regional Airport Commission	7164	11/18/21 1/11/22 1/12/22	MT0070-88 MT0070-88 MT0070-88	C		1,320.00				1,320.00	0.00
	6/1/22	WEED CONTROL		3/10/22	MT0070-89				3,234.40				3,234.40
	11/1/22	ROTATING BEACON TROUBLESHOOT		4/1/22	MT0070-90					1,000.00			1,000.00
MIDDLE PENINSULA (T:70) (8,406.88)	12/31/21	TRACTOR REPLACEMENT MIDDLE PENINSULA REGIONAL AIRPORT	6750	5/27/21 7/12/21	MT0057-40A MT0057-40A	C	29,550.00					29,550.00	0.00
	9/1/21	AWOS CPU CARD REPLACEMENT MIDDLE PENINSULA REGIONAL AIRPORT	6759	5/27/21 7/13/21	MT0057-41 MT0057-41	C	3,013.84					3,013.74	0.10
	11/1/21	LIGHTING REPAIRS FINAL DECREASE - SP Middle Peninsula Regional Airport	6930	5/27/21 9/21/21 9/22/21	MT0057-42 MT0057-42 MT0057-42	C	1,864.00 (640.00)					1,224.00	0.00
	5/1/22	AV GAS PUMP REPAIR		5/27/21	MT0057-43		6,738.34						6,738.34
	9/1/21	KUBOTA TIRES DECREASE FINAL - SP Middle Peninsula Regional Airport Authority	6822	5/27/21 8/9/21 8/10/21	MT0057-44 MT0057-44 MT0057-44	C	355.96 (131.70)					224.26	0.00
	6/1/22	FY22 AWOS INSP & REPAIR		7/1/21	MT0057-45		3,500.00						3,500.00
	11/1/21	AWOS OUTAGE EVAL FINAL DECREASE Middle Peninsula Regional Airport Authority	6980	8/9/21 10/18/21 10/18/21	MT0057-46 MT0057-46 MT0057-46	C	1,273.00 (950.00)					323.00	0.00
	5/31/22	REPLACE CEILOMETER (NB: Grant)		8/26/21	MT0057-47		34,180.72						34,180.72
VAB Package May 2022	3/1/22	EVAL & REPAIR RWY LIGHT Middle Peninsula Regional Airport Authority	7150	9/30/21 1/10/22	MT0057-48 MT0057-48	C	2,144.60					2,144.60	66 0.00

AIRPORT	Expiration	DESCRIPTION / VO. PAYEE	VO. NO.	DATE	PROJ. #	AIRPORT ALLOCATION STATUS				EXPENDITURE	UNEXP. BALANCE
						JULY-SEPT	OCT-DEC	JAN-MAR	APR-JUN		
	4/1/22	AWOS CPU CARD REPLACEMENT		1/20/22	MT0057-49			2,508.12			2,508.12
MOUNTAIN EMPIRE (T 75. Identified 6/16/16 61,300.90)	9/30/21	RWY 26 OBS REMOVAL (AIP) INCREASE - RWY 26 OBS REMOVAL (AIP) JTH & VC Smyth Wythe Airport Commission	6818	9/20/17 7/27/21 8/10/21	MT0031-37 MT0031-37 MT0031-37	C	817.05 2,730.00			3,547.05	0.00
	9/1/21	FY21 AWOS INSP & REPAIR CLOSED - ANJ		7/1/20 8/26/21	MT0031-56 MT0031-56	C	1,790.00 (1,790.00)				0.00
	9/1/21	OBSTRUCTION LIGHT WIRING REPAIR CLOSED AT AIRPORT REQUEST		10/1/20 8/23/21	MT0031-57 MT0031-57	W	396.00 (396.00)				0.00
	9/1/21	AIRFIELD SIGNAGE TROUBLESHOOT CLOSED AT AIRPORT REQUEST		5/27/21 8/26/21	MT0031-59 MT0031-59		400.00 (400.00)				0.00
	11/1/21	AIRFIELD LIGHTING REPLACEMENT LAMPS FINAL - DECREASE Smyth Wythe Airport Commission	6911	5/27/21 9/14/21 9/15/21	MT0031-60 MT0031-60 MT0031-60	C	1,200.00 (923.47)			276.53	0.00
	6/1/22	FY22 AWOS INSP & REPAIR		7/1/21	MT0031-62		3,500.00				3,500.00
	12/15/21	AWOS CPU AND MODEM UPDATE (95%) FINAL Smyth Wythe Airport Commission	6993	9/16/21 10/19/21 10/25/21	MT0031-63 MT0031-63 MT0031-63	C	3,778.63			3,778.63	0.00
		RUNWAY LIGHTS REPAIR KIT FINAL - DECREASE Smyth Wythe Airport Commission	7084	11/12/21 11/30/21 12/1/21	MT0031-64 MT0031-64 MT0031-64	C		103.76 (30.31)		73.45	0.00
	3/1/22	AWOS TEMP/DEW POINT PROBE REPAIR (95%) FINAL Smyth Wythe Airport Commission	7165	11/18/21 1/11/22 1/12/22	MT0031-65 MT0031-65 MT0031-65	C		1,870.31		1,870.31	0.00
	6/1/22	AWOS WIND SENSOR REPLACEMENT (95%) FINAL Smyth Wythe Airport Commission	7392	3/10/22 4/7/22 4/11/22	MT0031-66 MT0031-66 MT0031-66	C		653.13		653.13	0.00
NEW KENT (T: ?, F: 67%) 70,927.58	6/1/22	FY22 AWOS INSP & REPAIR New Kent County Board Of Supervisors	7168	7/1/21 1/12/22	MT0041-83 MT0041-83		3,500.00			1,662.50	1,837.50
	9/1/21	FUEL FARM PUMP DISPENSER MOTOR REPLACE (67%) CLOSED AT AIRPORT REQUEST		7/14/21 9/16/21	MT0041-84 MT0041-84	W	787.25 (787.25)				0.00
	3/1/22	RWY/TWY LIGHTING REPAIRS FINAL - DECREASE New Kent County Board Of Supervisors	7161	10/7/21 1/11/22 1/12/22	MT0041-85 MT0041-85 MT0041-85	C	795.15 (222.73)			572.42	0.00
	3/1/22	RWY 29 REIL REPAIR FINAL New Kent County Board Of Supervisors	7162	10/15/21 1/11/22 1/12/22	MT0041-86 MT0041-86 MT0041-86	C		231.65 (17.12)		214.53	0.00
	6/1/22	AWOS COMPUTER VOICE CIRCUIT BOARD		1/13/22	MT0041-87			5,928.00			5,928.00
NEW LONDON 75,000.00 Missing State Funding Annual Report Funding Report - N/A - no funds rec'd -VC		NEXT PROJECT			MT9083-03						0.00
NEW MARKET 70,360.00	9/1/21	FY21 AWOS INSP & REPAIR FINAL DECREASE - SP Roberto O Thomas	6794	7/1/20 7/26/21 7/27/21	MT9084-29 MT9084-29 MT9084-29	C	1,220.00 (80.00)			1,140.00	0.00
	6/1/22	FY22 AWOS INSP & REPAIR Robert O. Thomas Robert O. Thomas	7011 7374	7/1/21 10/28/21 3/30/22	MT9084-32 MT9084-32 MT9084-32		3,500.00			1,140.00 1,140.00	1,220.00
	4/1/22	AWOS OUTAGE FINAL DECREASE - SP Robert O Thomas	7183	1/10/22 1/18/22 1/19/22	MT9084-33 MT9084-33 MT9084-33	C		1,752.75 (760.00)		992.75	0.00
NEW RIVER VALLEY 70,360.00	9/1/21	FY21 AWOS INSP & REPAIR FINAL INCREASE - SP		7/1/20	MT0012-27	C	1,116.15 23.85				67 0.00

AIRPORT	Expiration	DESCRIPTION / VO. PAYEE	VO. NO.	DATE	PROJ. #	AIRPORT ALLOCATION STATUS				EXPENDITURE	UNEXP. BALANCE
						JULY-SEPT	OCT-DEC	JAN-MAR	APR-JUN		
		New River Valley A/P Commission	6785	7/27/21	MT0012-27					1,140.00	
	6/1/22	FY22 AWOS INSP & REPAIR		7/1/21	MT0012-28	C	3,500.00				
		New River Valley Airport Commission	7047	11/17/21	MT0012-28					2,280.00	1,220.00
	11/1/21	AWOS ASPIRATOR FAN	6910	7/14/21	MT0012-29	C	1,105.04			1,105.04	0.00
		New River Valley A/P Commission		9/15/21	MT0012-29						
	3/1/22	TAXIWAY LIGHT OUTAGE TROUBLESHOOT		12/10/21	MT0012-30	C		2,912.00			
		New River Valley Airport Commission	7207	1/24/22	MT0012-30					2,912.00	0.00
	4/1/22	EVAL ROTATING BEACON OUTAGE		1/20/22	MT0012-31	C			1,184.00		
		FINAL DECREASE - SP		1/31/22	MT0012-31				(640.00)		0.00
		New River Valley Airport	7214	1/31/22	MT0012-31					544.00	
	4/1/22	ROTATING BECAON REPAIR		1/27/22	MT0012-32	C			1,295.72		
		New River Valley Airport Commission	7353	3/21/22	MT0012-32					1,295.72	0.00
NEWPORT NEWS 75,000.00		NEXT PROJECT			MT0035-23		0.00				0.00
NORFOLK 75,000.00		NEXT PROJECT			MT0036-33		0.00				0.00
ORANGE COUNTY 69,898.65	9/1/21	AWOS SURGE SUPPRESSOR		5/27/21	MT0037-03	C	1,022.58				
		County of Orange	6771	7/20/21	MT0037-03					1,022.58	0.00
	9/1/21	REPAIR AWOS VHF RADIO		5/27/21	MT0037-04	C	1,338.77				
		DECREASE FINAL - SP		7/20/21	MT0037-04		(760.00)				0.00
		County of Orange	6772	7/20/21	MT0037-04					578.77	
	6/1/22	FY22 AWOS INSP & REPAIR		7/1/21	MT0037-05	C	3,500.00				
		County of Orange	7213	1/27/22	MT0037-05					1,140.00	1,220.00
		County of Orange	7445	4/27/22	MT0037-05					1,140.00	
RICHMOND EXECUTIVE (T) 67,513.63	12/15/21	VEGETATION MANAGEMENT		9/16/21	MT0007-69	C	3,772.00				
		FINAL		10/27/21	MT0007-69						0.00
		Chesterfield County	7029	11/10/21	MT0007-69					3,772.00	
	6/1/22	AIRFIELD LIGHTING/PCL RADIO SUPPLIES		2/17/22	MT0007-70			3,714.37			3,714.37
RICHMOND INTERNATIONAL 75,000.00		NEXT PROJECT			MT0043-91		0.00				0.00
ROANOKE 75,000.00		NEXT PROJECT			MT0045-56		0.00				0.00
SHANNON 69,753.89	6/1/22	FY22 AWOS INSP & REPAIR		7/1/21	MT9016-67	C	3,500.00				
		Shannon Airport, LLC	6757	7/12/21	MT9016-67					1,140.00	
		Shannon Airport, LLC	6953	10/6/21	MT9016-67					1,140.00	1,220.00
	10/1/21	RUNWAY EDGE LIGHT BULB PURCHASE		7/29/21	MT9016-68	C	307.22				
		Shannon Airport LLC	6824	8/10/21	MT9016-68					307.22	0.00
	11/1/21	EVALUATE ROTATION BEACON OUTAGE		7/29/21	MT9016-69	C	1,048.00				
		Shannon Airpprt LLC	6962	10/12/21	MT9016-69					1,048.00	0.00
	10/1/21	PLASI BULB PURCHASE		8/12/21	MT9016-70	C	240.41				
		Shannon Airport, LLC	6907	9/13/21	MT9016-70					240.41	0.00
	1/1/22	ROTATING BEACON BULB PURCHASE		10/22/21	MT9016-71	C		150.48			
		Shannon Airport LLC	7050	11/18/21	MT9016-71					150.48	0.00
SHENANDOAH VALLEY		NEXT PROJECT			MT0049-46		0.00				0.00
SMITH MT. LAKE (T: 91.2%) 74,558.65	10/1/21	WIND SOCK REPLACEMENT		8/9/21	MT9040-33	C	62.30				
		Smith Mountain Lake Airport LLC	6851	8/24/21	MT9040-33					62.30	0.00

VAB Package May 2022

AIRPORT	Expiration	DESCRIPTION / VO. PAYEE	VO. NO.	DATE	PROJ. #	AIRPORT ALLOCATION STATUS				EXPENDITURE	UNEXP. BALANCE		
						JULY-SEPT	OCT-DEC	JAN-MAR	APR-JUN				
	10/1/21	WEED CONTROL CHEMICALS FINAL INCREASE - SP Smith Mountain Lake Airport	6852	8/9/21 8/23/21 8/24/21	MT9040-34 MT9040-34 MT9040-34	C	366.30 12.75					379.05	0.00
STAFFORD (T: 56.5%, F: % 48,055.66	9/1/21	FY21 AWOS INSP & REPAIR Stafford Regional Airport	6870	7/1/20 8/31/21	MT0069-65 MT0069-65	C	3,500.00					3,420.00	80.00
	6/1/21	RUNWAY TAXIWAY LIGHT REPAIR CLOSED - SP STAFFORD REGIONAL AIRPORT AUTHORITY	6748	12/8/20 6/29/21 7/12/21	MT0069-67 MT0069-67 MT0069-67	C	2,007.72					2,007.72	0.00
	6/1/22	FY22 AWOS INSP & REPAIR Stafford Regional Airport	7152	7/1/21 1/10/22	MT0069-68 MT0069-68	W	3,500.00					1,140.00	2,360.00
	11/1/21	AWOS III WIND SENSOR REQUEST TO CLOSE - SP		9/9/21 11/16/21	MT0069-69		1,052.36 (1,052.36)						0.00
	4/1/22	RUNWAY AND TAXIWAY LIGHTING MAINTENANCE SP INCREASE Stafford Regional Airport Authority	7203	10/28/21 1/24/22 1/24/22	MT0069-70 MT0069-70 MT0069-70	C		3,620.00 45.90				3,665.90	0.00
	2/1/22	AUTOMATIC DOOR REPAIR FINAL DECREASE - SP Stafford Regional Airport	7153	12/2/21 1/5/22 1/10/22	MT0069-71 MT0069-71 MT0069-71	C		1,600.00 (694.98)				905.02	0.00
	3/1/22	V-DITCH CLEANING Stafford Regional Airport	7154	12/10/21 1/10/22	MT0069-72 MT0069-72	C		2,800.00				2,800.00	0.00
	4/1/22	GENERATOR BUILDING DOOR REPAIR Stafford Regional Airport	7352	1/6/22 3/21/22	MT0069-73 MT0069-73	C			1,200.00			1,200.00	0.00
	4/1/22	AIRPORT MAIN ACCESS ROAD REPAIR Stafford Regional Airport	7329	1/6/22 3/16/22	MT0069-74 MT0069-74	C			2,800.00			2,800.00	0.00
	4/1/22	AWOS COMPUTER GRAPHICS CARD REPAIR Stafford Regional Airport Authority		1/6/22 1/24/22	MT0069-75 MT0069-75	C			1,002.25			1,002.25	0.00
	4/1/22	AWOS COMPUTER REPLACEMENT Stafford Regional Airport Authority	7358	1/20/22 3/21/22	MT0069-76 MT0069-76	C			5,563.45			5,563.45	0.00
SUFFOLK FF: 33% 71,500.00	6/1/22	FY22 AWOS INSP & REPAIR City of Suffolk	7078	7/1/21 12/1/21	MT0050-54 MT0050-54		3,500.00					1,140.00	2,360.00
		NEXT PROJECT			MT0050-55								
TANGIER ISLAND 68,331.16	9/1/21	FY20 AWOS INSP & REPAIR CLOSE - ANJ		7/1/19 9/14/21	MT0051-13 MT0051-13	C	1,395.00 (1,395.00)						0.00
	3/1/22	FY21 AWOS INSP & REPAIR FINAL - DECREASE Town OF Tangier	7294	7/1/20 2/23/22 2/28/22	MT0051-14 MT0051-14 MT0051-14	C	2,075.00 (650.00)					1,425.00	0.00
	6/1/22	FY22 AWOS INSP & REPAIR Town of Tangier	7248	7/1/21 2/8/22	MT0051-16 MT0051-16		3,500.00					1,425.00	2,075.00
	3/1/22	AWOS DISPLAY REPLACEMENT FINAL - DECREASE Town of Tangier	7249	7/14/21 2/4/22 2/8/22	MT0051-17 MT0051-17 MT0051-17	C	2,385.09 (641.25)					1,743.84	0.00
TAPPAHANNOCK-ESSEX 66,175.89	11/1/22	FY22 AWOS INSP & REPAIR Essex County Airport Authority Essex County Airport Authority	7200 7417	7/1/21 1/24/22 4/20/22	MT0081-73 MT0081-73 MT0081-73		3,500.00					1,140.00 1,140.00	1,220.00
	9/1/21	WEED CONTROL Essex County Airport Authority	6871	7/14/21 8/31/21	MT0081-74 MT0081-74	C	798.40					798.40	0.00
	2/1/22	REIL BULB Essex County Airport Authority	7205	11/4/21 1/24/22	MT0081-75 MT0081-75	C		702.51				702.51	0.00
	6/1/22	EVAL AVIMET COMPUTER		3/4/22	MT0081-76				980.00				980.00
VAB Package May 2022	6/1/22	FIRE ALARM PANEL FINAL DECREASE - SP		3/4/22	MT0081-77	C			2,868.80 (25.60)				69

AIRPORT	Expiration	DESCRIPTION / VO. PAYEE	VO. NO.	DATE	PROJ. #	AIRPORT ALLOCATION STATUS				EXPENDITURE	UNEXP. BALANCE
						JULY-SEPT	OCT-DEC	JAN-MAR	APR-JUN		
		Essex County Airport Authority	7381	4/6/22	MT0081-77					2,843.20	0.00
	7/1/22	AWOS COMPUTER VOICE CARD		4/14/22	MT0081-78				4,824.45		4,824.45
TAZEWELL COUNTY (T 83 Notified 9/20/17 of OBS off-airport 65,943.66	9/1/21	FY21 AWOS INSP & REPAIR Tazewell Cpurty Airport Authority CLOSE - ANJ	6917	7/1/20 9/20/21 3/24/22	MT0053-10 MT0053-10 MT0053-10	C	3,500.00 (80.00)			3,420.00	0.00
	9/1/21	REPLACE HMP 155 PAPI DISAPPROVED (WORK INITIATED PRIOR APPROVAL)		5/27/21 8/17/21	MT0053-11 MT0053-11	D	1,225.01 (1,225.01)				0.00
	6/1/22	FY22 AWOS INSP & REPAIR Tazewell County Airport Authority	7066	7/1/21 11/29/21	MT0053-12 MT0053-12		3,500.00			1,140.00	2,360.00
	7/1/22	MOWER REPAIR		4/1/22	MT0053-13				2,136.34		2,136.34
TWIN COUNTY (F - 67%, T 62,685.30	9/1/21	FY21 AWOS INSP & REPAIR		7/1/20	MT0020-46	C	935.00				935.00
	9/1/21	PAPI REPAIR Twin County Airport Commission	6823	5/27/21 8/10/21	MT0020-48 MT0020-48	C	2,590.40			2,590.40	0.00
	11/1/22	FY22 AWOS INSP & REPAIR Twin County Airport Commission Twin County Airport Commission	6957 7176	7/1/21 10/12/21 1/14/22	MT0020-49 MT0020-49 MT0020-49		3,500.00			855.00 855.00	1,790.00
	11/1/21	2021 BULB REPLACEMENT Twin County Airport Commission	6872	7/14/21 8/31/21	MT0020-50 MT0020-50	C	139.20			139.20	0.00
	9/1/21	2021 WINDSOCK REPLACEMENT Twin County Airport Commission FINAL DECREASE - SP	6816	7/14/21 8/10/21	MT0020-51 MT0020-51	C	203.56 (3.20)			200.36	0.00
	5/1/22	RUNWAY LIGHTING FINAL DECREASE - SP Twin County Airport Commission	7310	2/17/22 3/2/22 3/2/22	MT0020-52 MT0020-52 MT0020-52	C		225.36 (42.64)		182.72	0.00
	6/1/22	AWOS WEATHER SENSOR Twin County Airport Commission	7333	2/25/22 3/16/22	MT0020-53 MT0020-53	C		760.00		760.00	0.00
	6/1/22	MAIN PEDESTRIAN ACCESS GATE Twin County Airport Commission	7330	3/4/22 3/16/22	MT0020-54 MT0020-54	C		437.90		437.90	0.00
	6/1/22	AWOS WIND SENSOR Twin County Airport Commission	7354	3/10/22 3/21/22	MT0020-55 MT0020-55	C		653.12		653.12	0.00
	11/1/22	VEGETATION CONTROL		3/17/22	MT0020-56			2,916.00			2,916.00
	7/1/22	AVGAS NOZZLE REPAIR Twin County Airport Commission	7414	4/7/22 4/20/22	MT0020-57 MT0020-57	C			667.90	667.90	(0.00)
VA. HIGHLANDS 66,428.70	6/1/22	FY22 AWOS INSP & REPAIR Virginia Highlands Airport Authority Virginia Highlands Airport Authority	7079 7320	7/1/21 12/1/21 3/9/22	MT0001-70 MT0001-70 MT0001-70		3,500.00			1,140.00 1,140.00	1,220.00
	9/1/21	HERBICIDE APPLICATION 2021 CLOSED AT AIRPORT REQUEST - WORK COMPLETED		7/14/21 7/19/21	MT0001-71 MT0001-71	W	3,658.62 (3,658.62)				0.00
	9/1/21	AWOS DIAL-IN REPAIR FINAL Virginia Highlands Airport Authority	6808	7/14/21 7/28/21 8/3/21	MT0001-72 MT0001-72 MT0001-72	C	1,083.00			1,083.00	0.00
	3/1/22	REPLACE STROBE LIGHT FLASH TUBE FINAL Virginia Highlands Airport Authority	7163	12/9/21 1/11/22 1/12/22	MT0001-73 MT0001-73 MT0001-73	C		329.60		329.60	0.00
	6/1/22	WEED CONTROL		3/10/22	MT0001-74			3,658.70			3,658.70
VA. TECH (T: ?, F: 50%) 67,814.66	6/1/22	FY22 AWOS INSP & REPAIR Virginia Tech Montgomery Regional Airport Authority Virginia Tech Montgomery Regional Airport Authority	6928 7206	7/1/21 9/22/21 1/24/22	MT0002-59 MT0002-59 MT0002-59		3,500.00			1,140.00 1,140.00	1,220.00
VAB Package May 2022											70

AIRPORT	Expiration	DESCRIPTION / VO. PAYEE	VO. NO.	DATE	PROJ. #	AIRPORT ALLOCATION STATUS				EXPENDITURE	UNEXP. BALANCE	
						JULY-SEPT	OCT-DEC	JAN-MAR	APR-JUN			
	9/1/21	Taxiway Light Replacement Virginia Tech Montgomery Regional Airport Authority	6821	7/14/21 8/10/21	MT0002-60 MT0002-60	C	427.70				427.70	0.00
	4/1/22	REPAIR RAMP FLOOD LIGHTS Virginia Tech Montgomery Regional Airport Authority	7332	10/22/21 3/16/22	MT0002-61 MT0002-61	C		2,200.34			2,200.34	0.00
	6/1/22	REPAIR 4-LED TAXIWAY LIGHTS REDUCE FINAL - SP Virginia Tech Montgomery Regional Airport Authority	7393	1/20/22 4/11/22 4/11/22	MT0002-62 MT0002-62 MT0002-62	C			843.62 (11.68)		831.94	0.00
	4/1/22	REPLACEMENT BULBS PAPIS AND OBS LGHTS Virginia Tech Montgomery Regional Airport Authority	7311	2/7/22 3/2/22	MT0002-63 MT0002-63	C			225.36		225.36	0.00
WAKEFIELD Obstruction mitigated 4/27/18 75,000.00		NEXT PROJECT			MT9071-14		0.00					0.00
WARRENTON 58,816.88	9/30/23	RUNWAY SEAL COAT & MARKING (6% STATE/FED. PROJECT)		10/3/19	MT0068-03	C	1,509.58					1,509.58
	11/1/22	FY22 AWOS INSP & REPAIR		7/1/21	MT0068-10		3,500.00					
	10/13/21	Fauquier County	6965	10/13/21	MT0068-10						2,280.00	1,220.00
		Fauquier County	7227	2/2/22	MT0068-10						1,140.00	
		Increase per AJ		5/3/22			1,140.00					
	9/1/21	VEGETATION MANAGEMENT 2021 FINAL - DECREASE Fauquier County	6875	7/14/21 8/25/21 8/31/21	MT0068-11 MT0068-11 MT0068-11	C	3,948.80 (640.00)				3,308.80	0.00
	9/1/21	RWY 15 PAPI REGULATOR REPAIR FINAL Fauquier County	6876	7/14/21 8/25/21 8/31/21	MT0068-12 MT0068-12 MT0068-12	C	1,080.74				1,080.74	0.00
	11/1/21	RWY 33 PAPI TIMING TRIGGER REPAIR FINAL Fauquier County	6877	7/29/21 8/25/21 8/31/21	MT0068-13 MT0068-13 MT0068-13	C	1,695.20				1,695.20	0.00
		VEGETATION MANAGEMENT FY22		4/7/22	MT0068-14							3,948.80
WILLIAM M. TUCK 89,720.56	6/1/22	FY22 AWOS INSP & REPAIR County of Halifax	7328	7/1/21 3/16/22	MT0047-48 MT0047-48		3,500.00				1,140.00	2,360.00
	5/1/22	AWOS MECHANICAL WIND SENSOR		8/9/21	MT0047-49	C	6,779.44					6,779.44
WILLIAMSBURG Monitor Airport Condition 62,777.00	9/1/21	FY21 AWOS INSP & REPAIR Williamsburg- Jamestown Airport Inc	6773	7/1/20 7/20/21	MT9010-70 MT9010-70	C	2,550.00				950.00	1,600.00
	6/1/22	FY22 AWOS INSP & REPAIR Williamsburg - Jamestown Airport	7312	7/1/21 3/2/22	MT9010-75 MT9010-75		3,500.00				1,140.00	2,360.00
	11/1/21	ANNUAL WEED CONTROL Williamsburg - Jamestown Airport	6954	7/14/21 10/6/21	MT9010-76 MT9010-76	C	3,604.00				3,604.00	0.00
	10/1/21	TERMINAL ROOF CONDUIT REPAIR Williamsburg Jamestown Airport Inc	6929	8/12/21 9/22/21	MT9010-77 MT9010-77	C	1,296.00				1,296.00	0.00
	11/1/21	AWOS CEILOMETER EVAL Williamsburg jamestown	7013	8/26/21 10/28/21	MT9010-78 MT9010-78	C	1,273.00				1,273.00	0.00
	6/1/22	ANNUAL WEED CONTROL		3/10/22	MT9010-79				3,604.00			3,604.00
	6/1/22	VEGETATION MANAGEMENT Williamsburg- Jamestown Airport	7444	3/17/22 4/27/22	MT9010-80 MT9010-80				3,640.00		2,840.00	800.00
WINCHESTER 70,360.00	9/1/21	FY21 AWOS INSP & REPAIR Winchester Regional Airport Authority CLOSE - ANJ	6749	7/1/20 7/12/21 3/24/22	MT0059-28 MT0059-28 MT0059-28	C	1,220.00 (80.00)				1,140.00	0.00
	6/1/22	FY22 AWOS INSP & REPAIR Winchester Regional Airport Authority	7290	7/1/21 2/23/22	MT0059-30 MT0059-30		3,500.00				2,280.00	1,220.00
VAB Package May 2022	12/1/21	FY22 AIRFIELD LAMP RESTOCK		10/7/21	MT0059-31	C		1,689.12				71

DEPARTMENT OF AVIATION
RURAL AIRPORT RUNWAY REHAB STATUS
FY 19 - FY 21
as of Feb 22, 2019

AIRPORT	DESCRIPTION	DATE	PROJECT #	ALLOCATION	GRANT	TA BALANCE
CHASE CITY	Runway Rehabilitation (Prelim Design & Geotech)	4/1/20	RA0005-01	25,000.00	0.00	25,000.00
EAGLES NEST	Runway Rehabilitation (Design/Construction)	7/17/19	RA9089-01 C	172,687.00		
	Runway Rehabilitation (Design/Construction)	7/26/19 *	RA9089-01		172,687.00	0.00
	Runway Rehabilitation (Design/Construction)	2/13/20	RA9089-01	19,183.00		
	Runway Rehabilitation (Design/Construction)	2/20/24	RA9089-01		19,183.00	0.00
GORDONSVILLE	Runway Rehabilitation (Constr)	3/23/2021	RA9070-01	445,000.00		
	Runway Rehabilitation (Constr)	4/7/2021	RA9070-01		445,000.00	0.00
NEW MARKET	RWY REHAB DESIGN/BID	3/4/2019	RA9084-01	5,000.00		
	RWY REHAB DESIGN/BID	3/8/2019	RA9084-01		5,000.00	0.00
NEW MARKET	Runway Rehabilitation (Design/Bid)	2/13/20	RA9084-01 C	890.00		
	Runway Rehabilitation (Design/Bid)	2/24/20	RA9084-01		890.00	0.00
	Runway Rehabilitation (Construction)	1/30/20	RA9084-02	323,000.00		
	Runway Rehabilitation (Construction) - Increase for construction admin	2/14/20	RA9084-02	7,000.00		
	Runway Rehabilitation (Construction)	6/29/20	RA9084-02		330,000.00	0.00
TOTAL PLACED UNDER ALLOCATION				997,760.00		
TOTAL PLACED UNDER GRANT					972,760.00	
OPEN T.A. BALANCE AT 02/22/19						25,000.00

A	B	C	D	E	F	G	H	I	J	K	L	M	N	O	P	Q	R	S	T	U	V	
1	DEPARTMENT OF AVIATION																					
2	AVIATION AND AIRPORTS PROMOTION PROGRAM																					
3	FYE June 30, 2021																					
4																						
5	ORIGINAL APPROPRIATION 2021-2022 (FY21)								\$350,000.00													
6	PLUS PRIOR YEAR COMMITMENTS (FY21)								\$0.00													
7	TOTAL APPROPRIATION								\$350,000.00													
8																						
9	UNALLOCATED BALANCE FY22								\$0.00													
10																						
11	Airport	Date	Grant No.	Description/Notes	Pre T/A Date	Pre T/A \$	T/A Date	T/A \$	Grant Date	Grant \$	Expenditure 1	Expenditure 2	Expenditure 3	Expenditure 4	Unexpended Balance	Carryover	Date	Voucher #	Returned to Fund	Grant Expiration	Final RSVP	Grant Closed
12	Accomack														\$0.00							
13	Charlottesville	12/22/2021	PR0004-02				12/29/2021		2/15/2022	\$35,000.00					\$35,000.00						5/13/22	
14	Culpeper	8/9/2021	PR0010-03		8/9/2021		8/9/2021		8/17/2021	\$10,000.00					\$10,000.00						4/29/22	
15	Danville	8/9/2021	PR0011-05		8/9/2021		8/9/2021		8/18/2021	\$7,500.00	\$5,570.92				\$1,929.08		2/8/2022	#7247			4/29/22	
16	Front Royal Warren														\$0.00							
17	Hampton Roads														\$0.00							
18	Hummel Field	8/9/2021	PR0076-04		8/9/2021		8/9/2021		8/20/2021	\$10,000.00	\$9,403.68				\$596.32		4/14/2022	#7410				
19	Hot Springs	8/9/2021	PR0024-03		8/9/2021		10/13/2021		10/25/2021	\$10,000.00					\$10,000.00							
20	Leesburg	8/9/2021	PR0027-03		8/9/2021		8/9/2021		9/17/2021	\$10,000.00	\$10,000.00				\$0.00		1/7/2021	#7146	\$0.00		4/29/22	12/6/2021 2/15/2022
21	Lonesome Pine														\$0.00							
22	Louisia														\$0.00							
23	Lynchburg	8/9/2021	PR0029-04		8/9/2021		8/9/2021		8/25/2021	\$35,000.00	\$19,455.86				\$0.00		4/14/2022	#7409			5/13/22	
24	Manassas														\$0.00							
25	Mecklenburg Brunswick														\$0.00							
26	Middle Peninsula														\$0.00							
27	New Kent														\$0.00							
28	Newport News Williamsburg	8/9/2021	PR0035-05		8/9/2021		8/9/2021		8/9/2021	\$35,000.00	\$35,000.00				\$0.00		1/7/2021	#7144	\$0.00		5/13/22	12/6/2021 2/15/2022
29	Norfolk	9/28/2021	PR0036-04		9/28/2021		9/28/2021		10/5/2021	\$35,000.00					\$35,000.00						5/13/22	
30	Richmond Executive Chesterfield	8/9/2021	PR0007-04		8/9/2021		8/9/2021		8/24/2021	\$10,000.00					\$10,000.00						5/6/22	
31	Richmond International	8/9/2021	PR0043-04		8/9/2021		8/9/2021		8/9/2021	\$35,000.00	\$26,050.33				\$8,949.67		1/26/2022	#7211			5/13/22	
32	Roanoke Blacksburg	8/9/2021	PR0045-07		8/9/2021		8/9/2021		8/17/2021	\$35,000.00	\$35,000.00				\$0.00		1/24/2021	#7201	\$0.00		5/13/22	1/7/2022 2/17/2022
33	Roanoke Blacksburg	1/18/2022	PR0045-08		1/27/2022		2/15/2022		2/15/2022	\$29,000.00					\$0.00							
34	Shenandoah Valley	8/9/2021	PR0049-05		8/9/2021		8/16/2021		8/16/2021	\$35,000.00	\$24,220.50	\$5,441.39	\$5,338.11		\$0.00		1/6/2021-02/02/22 04/	#7145, #7230 #7411			5/13/22	
35	Stafford	11/12/2021	PR0069-01		11/18/2021		11/18/2021		12/14/2021	\$10,000.00					\$10,000.00						5/16/21	
36	Tappahannock-Essex														\$0.00							
37	Tazewell														\$0.00							
38	VA Highlands														\$0.00							
39	VA Tech/Montgomery														\$0.00							
40	Warrenton-Fauquier	9/28/2021	PR0068-03		8/9/2021		9/28/2021		10/20/2021	\$1,000.00					\$1,000.00							
41	Winchester	8/9/2021	PR0059-03		8/9/2021		8/17/2021		8/17/2021	\$7,500.00	\$352.00				\$7,148.00		12/7/2021	#7098			4/29/22	
42															\$0.00							
43															\$0.00							
44															\$0.00							
45															\$0.00							
46															\$0.00							
47															\$0.00							
48															\$0.00							
49															\$0.00							
50															\$0.00							
51															\$0.00							
52															\$0.00							
53															\$0.00							
54															\$0.00							
55															\$0.00							
56															\$0.00							
57															\$0.00							
58															\$0.00							
59															\$0.00							
60															\$0.00							
61															\$0.00							
62															\$0.00							
63						\$0.00		\$0.00		\$350,000.00					\$129,623.07	\$0.00				\$0.00		

AIR CARRIER / RELIEVER AIRPORTS - DISCRETIONARY FUNDS
RECOMMENDED PROJECTS

FUNDED

PRIORITY NO.	AIRPORT NAME	DESCRIPTION	FEDERAL AMOUNT	STATE DISCR. AMOUNT	LOCAL AMOUNT	TOTAL PROJECT AMOUNT
177	Twin County Airport	Rotating Beacon Replacement	\$0.00	\$12,012.00	\$3,004.00	\$15,016.00
171	Blue Ridge Regional Airport	West Apron Crack Fill & Sealcoat (Construction)	\$0.00	\$34,305.00	\$8,577.00	\$42,882.00
148	Virginia Tech - Montgomery Executive Airport	Slope Mower	\$0.00	\$17,623.75	\$17,623.75	\$35,247.50
115	Lee County Airport	Runway 7-25 Airfield Lighting Rehabilitation (Design)	\$106,200.00	\$9,440.00	\$2,360.00	\$118,000.00
REGION TOTALS:			\$106,200.00	\$73,380.75	\$31,564.75	\$211,145.50

COMMONWEALTH AVIATION FUND
 FUNDING REQUEST SUMMARY
 VAB DATE: 05/25/2022

Airport: Blue Ridge Regional Airport
 Region: 1
 Name: Ms. Sophie Vance

Sponsor: Blue Ridge Airport Authority
 Contact: Mr. W. Lee Hussey II, Chairman
 Phone: 276-340-6455

State Funding Summary		
	Requested	Recommended
Entitlement	\$0.00	\$0.00
Air Carrier/Reliever Discretionary	\$34,305.00	\$34,305.00
General Aviation Discretionary	\$0.00	\$0.00
TOTALS	\$34,305.00	\$34,305.00

Unmitigated Obstructions

Based Aircraft:	45
Annual Operations:	23,300
Service Role:	RL

Development Program Projects									
Description	Priority	Project Cost	Federal	Requested Funding			Recommended Funding		
				State	Local	Federal	State	Local	
West Apron Crack Fill & Sealcoat (Construction)	171	\$42,882.00		\$34,305.00	\$8,577.00		\$34,305.00	\$8,577.00	
TOTALS		\$42,882.00	\$0.00	\$34,305.00	\$8,577.00	\$0.00	\$34,305.00	\$8,577.00	

Remarks: West Apron Crack Fill & Sealcoat (Construction)
 Staff recommends approval.

To: Virginia Aviation Board
From: Blue Ridge Regional Airport
Date: May, 2022

REQUEST 1: Crack Seal-West Apron and Taxilanes

Description: The Blue Ridge Regional Airport West Apron and taxilanes leading to the West Apron are in need of maintenance. This project includes 7,747-ft of crack filling and 156,527sf of seal coat.

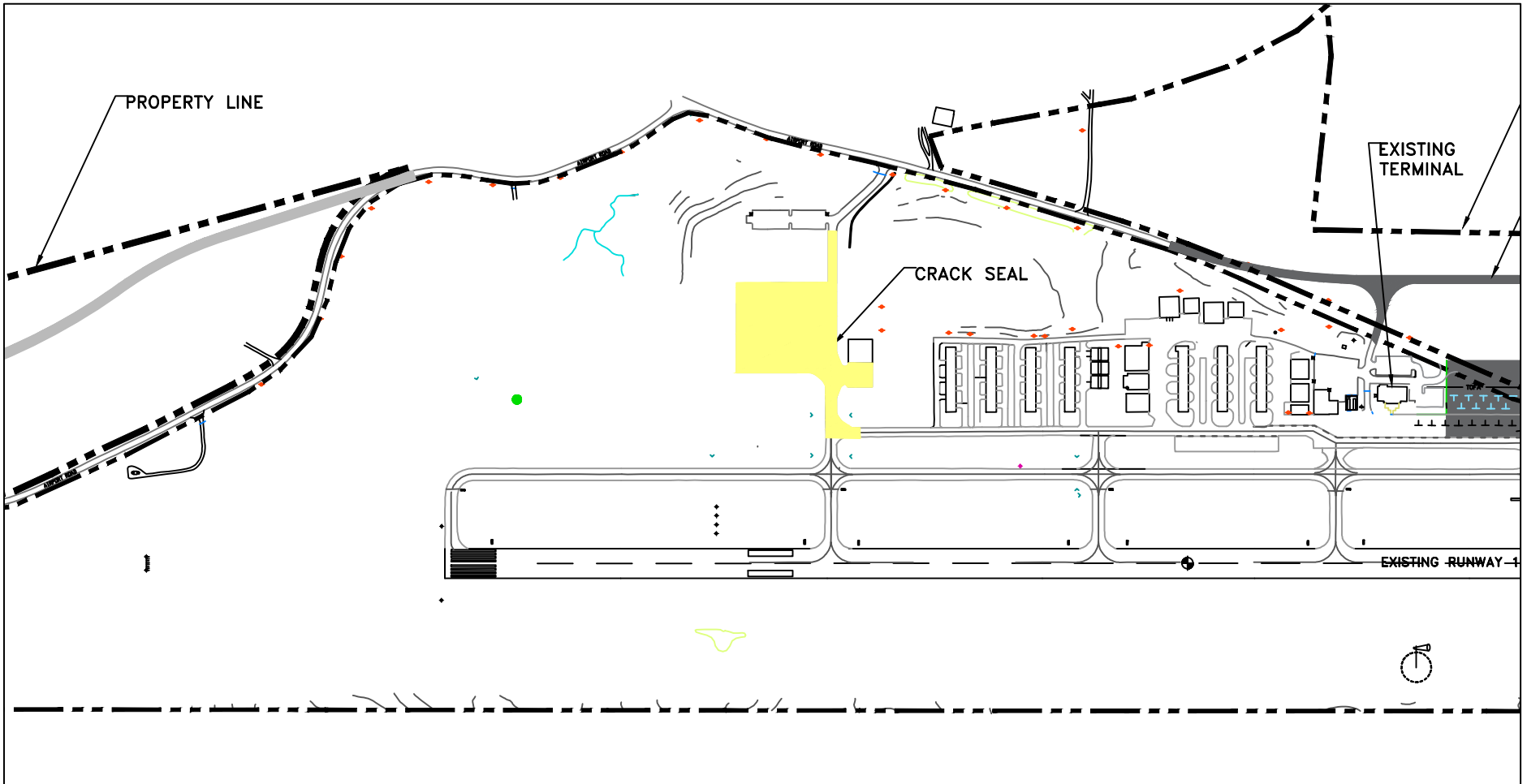

MAY VAB

BLUE RIDGE REGIONAL AIRPORT
 MARTINSVILLE, VIRGINIA
 PAVEMENT CRACK SEAL
 WEST APRON AND TAXILANES

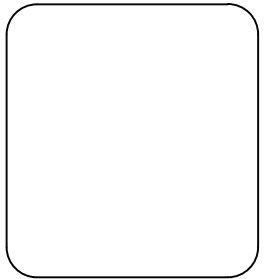

COMMONWEALTH AVIATION FUND
 FUNDING REQUEST SUMMARY
 VAB DATE: 05/25/2022

Airport: Lee County Airport
 Region: 1
 Name: Ms. Sophie Vance

Sponsor: County of Lee
 Contact: Mr. D. Dane Poe , County Administrator
 Phone: 276-346-7714

State Funding Summary		
	Requested	Recommended
Entitlement	\$0.00	\$0.00
Air Carrier/Reliever Discretionary	\$9,440.00	\$9,440.00
General Aviation Discretionary	\$0.00	\$0.00
TOTALS	\$9,440.00	\$9,440.00

Unmitigated Obstructions

Based Aircraft:	7
Annual Operations:	3,481
Service Role:	RL

Development Program Projects								
Projects			Requested Funding			Recommended Funding		
Description	Priority	Project Cost	Federal	State	Local	Federal	State	Local
Runway 7-25 Airfield Lighting Rehabilitation (Design)	115	\$118,000.00	\$106,200.00	\$9,440.00	\$2,360.00	\$106,200.00	\$9,440.00	\$2,360.00
TOTALS		\$118,000.00	\$106,200.00	\$9,440.00	\$2,360.00	\$106,200.00	\$9,440.00	\$2,360.00

Remarks: Runway 7-25 Airfield Lighting Rehabilitation (Design)
 Staff recommends approval.

**LEE COUNTRY AIRPORT
PROJECT NARRATIVES FISCAL YEAR 2022
May 2022 VAB Meeting**

Rehabilitate Airfield Electrical Systems

The scope of this project includes the design and bidding phase services for the Rehabilitate Airfield Electrical Systems Project. The runway lights and signs are 20 years old and need to be replaced with new LED lights and signs. In addition to the lights and signs, the project will also include replacing the PAPI, REILs, and wind cone with new LED models.

Construction Funding will be requested under a separate grant. Proposed Funding Allocation – FAA 90% State 8%, Local 2%

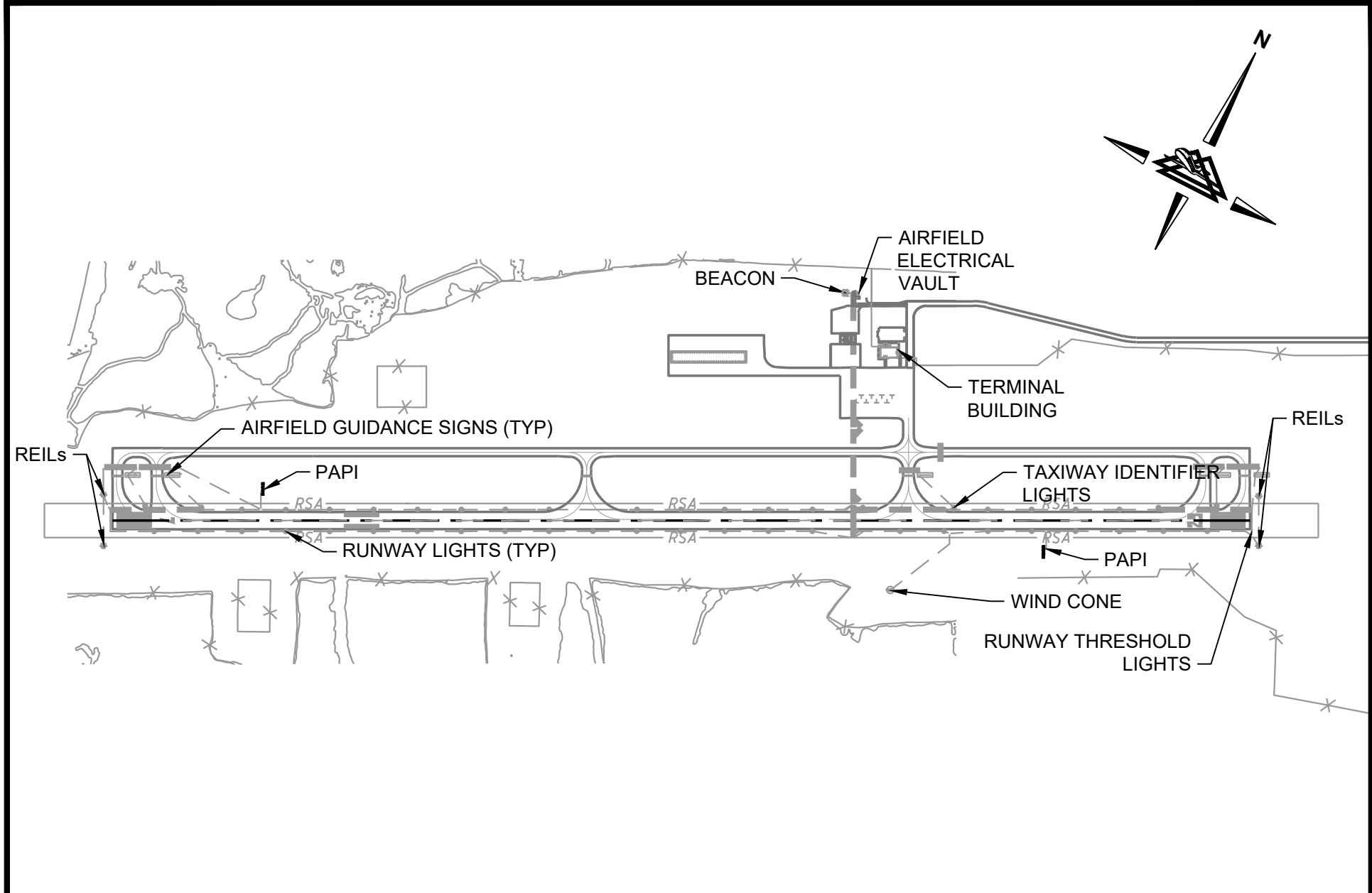

REHABILITATE AIRFIELD ELECTRICAL SYSTEM LEE COUNTY AIRPORT

EXHIBIT
1
81

COMMONWEALTH AVIATION FUND
 FUNDING REQUEST SUMMARY
 VAB DATE: 05/25/2022

Airport: Twin County Airport
 Region: 1
 Name: Ms. Sophie Vance

Sponsor: Twin County Airport Commission
 Contact: Mr. Tom Jones , Chair
 Phone: 276-236-6473

State Funding Summary		
	Requested	Recommended
Entitlement	\$0.00	\$0.00
Air Carrier/Reliever Discretionary	\$12,012.00	\$12,012.00
General Aviation Discretionary	\$0.00	\$0.00
TOTALS	\$12,012.00	\$12,012.00

Unmitigated Obstructions

Based Aircraft:	23
Annual Operations:	8,813
Service Role:	GC

Development Program Projects									
Projects			Requested Funding			Recommended Funding			
Description	Priority	Project Cost	Federal	State	Local	Federal	State	Local	
Rotating Beacon Replacement	177	\$15,016.00		\$12,012.00	\$3,004.00		\$12,012.00	\$3,004.00	
TOTALS		\$15,016.00	\$0.00	\$12,012.00	\$3,004.00	\$0.00	\$12,012.00	\$3,004.00	

Remarks: Rotating Beacon Replacement
 Staff recommends approval.

Twin County Airport Commission
504 Hangar Road
Hillsville, Virginia 24343-5264
Telephone (276) 728-4504 Facsimile (276) 728-4544
E-Mail: twincountyairport@gmail.com

March 15, 2022

Amy Wells
Virginia Department of Aviation
5702 Gulfstream Road
Richmond, VA 23250-2422

Dear Ms. Wells,

As requested, Twin County Airport would propose to provide equipment and labor for the installation of one L802A Airport Beacon due to our current beacons unserviceability and last known refurbishment in the 1990's, according to the manufacturer. Beacon Model DCB 224 is our existing model.

Twin County Airport has an older latus tower structure standing approximately twenty five feet tall with wooden platform on top to support the existing beacon. The picture below depicts the beacons location at the airport being fifty feet south of the AWOS or two hundred seventy five feet east of fuel farm, beacon outlined by a red circle.



The DCB 224 weighs approximately a hundred pounds and will be lowered to the ground utilizing a boom lift. The new L802A Airport Beacon will then be installed upon existing platform and electrical connections terminated and secured properly.

Twin County Airport has provided two quotes by contractors (Austin Electrical Construction INC. and RCS Communications) to show industry standards for current mobilization, labor, and material costs associated with this particular project. With your support we would like to cover all costs associated with labor and equipment, expecting reimbursement of the materials cost totaling \$12,128. (See attached quote from Halibrite for material cost).

We appreciate your support and look forward to your decision.

Sincerely,

A handwritten signature in black ink, appearing to read "Michael Lawson". The signature is fluid and cursive, with a long horizontal stroke at the end.

Michael Lawson
Airport Manager
Twin County Airport

COMMONWEALTH AVIATION FUND
 FUNDING REQUEST SUMMARY
 VAB DATE: 05/25/2022

Airport: Virginia Tech - Montgomery Executive Airport
 Region: 1
 Name: Ms. Sophie Vance

Sponsor: Virginia Tech-Montgomery Regional Airport Authority
 Contact: Mr. Keith Holt , Manager
 Phone: 540-231-4444

State Funding Summary		
	Requested	Recommended
Entitlement	\$0.00	\$0.00
Air Carrier/Reliever Discretionary	\$17,623.75	\$17,623.75
General Aviation Discretionary	\$0.00	\$0.00
TOTALS	\$17,623.75	\$17,623.75

Unmitigated Obstructions

Based Aircraft:	46
Annual Operations:	22,224
Service Role:	GR

Development Program Projects									
Description	Priority	Project Cost	Federal	Requested Funding			Recommended Funding		
				State	Local	Federal	State	Local	
Slope Mower	148	\$35,247.50		\$17,623.75	\$17,623.75		\$17,623.75	\$17,623.75	
TOTALS		\$35,247.50	\$0.00	\$17,623.75	\$17,623.75	\$0.00	\$17,623.75	\$17,623.75	

Remarks: Slope Mower
 Staff recommends approval.

Virginia Tech/Montgomery Executive Airport – BCB

PURCHASE SLOPE MOWER NARRATIVE

The Virginia Tech/Montgomery Executive Airport advertised specifications and accepted bids for the purchase of a slope mower. The specifications included the ability of being rated to safely mow a slope of at least 22-degrees continuously, with at least a 60” wide cutting path. The purchase of this slope mower will allow airport staff to safely mow and maintain sloped areas around the airfield.

Example:



Region: 2

AIR CARRIER / RELIEVER AIRPORTS - DISCRETIONARY FUNDS
RECOMMENDED PROJECTS

FUNDED

PRIORITY NO.	AIRPORT NAME	DESCRIPTION	FEDERAL AMOUNT	STATE DISCR. AMOUNT	LOCAL AMOUNT	TOTAL PROJECT AMOUNT
170	Gordonsville Municipal Airport	Runway, Taxiway & Apron Rehabilitation (Construction) INCREASE	\$0.00	\$273,082.00	\$68,271.00	\$341,353.00
REGION TOTALS:			\$0.00	\$273,082.00	\$68,271.00	\$341,353.00

COMMONWEALTH AVIATION FUND
 FUNDING REQUEST SUMMARY
 VAB DATE: 05/25/2022

Airport: Gordonsville Municipal Airport
 Region: 2
 Name: Ms. Victoria Cox

Sponsor: Town of Gordonsville
 Contact: Ms. Deborah Kendall , Town Manager
 Phone: 540-832-2233

State Funding Summary		
	Requested	Recommended
Entitlement	\$0.00	\$0.00
Air Carrier/Reliever Discretionary	\$273,082.00	\$273,082.00
General Aviation Discretionary	\$0.00	\$0.00
TOTALS	\$273,082.00	\$273,082.00

Unmitigated Obstructions

Based Aircraft:	17
Annual Operations:	10,669
Service Role:	RL

Development Program Projects									
Projects			Requested Funding			Recommended Funding			
Description	Priority	Project Cost	Federal	State	Local	Federal	State	Local	
Runway, Taxiway & Apron Rehabilitation (Construction) - INCREASE	170	\$341,353.00		\$273,082.00	\$68,271.00		\$273,082.00	\$68,271.00	
TOTALS		\$341,353.00	\$0.00	\$273,082.00	\$68,271.00	\$0.00	\$273,082.00	\$68,271.00	

Remarks: Runway, Taxiway & Apron Rehabilitation (Construction) - INCREASE
 Staff recommends approval.

**AIRPORT CAPITAL IMPROVEMENT PROGRAM
PROGRAM NARRATIVE
GORDONSVILLE MUNICIPAL AIRPORT (GVE)**

The following program narrative addresses the project description and justification for the current year of the Airport Capital Improvement Program.

1 – Runway, Taxiway & Apron Rehabilitation - Construction INCREASE

This project was initially bid in August 2020 but the necessary state funding was not approved/available until the March 2021 Virginia Aviation Board meeting. Delays in funding and obtaining DEQ approvals, supply chain issues, and the DOAV Liquid Asphalt Escalation clause included in the bid package have resulted in an increase to the estimated construction cost. After receiving an updated cost from the original low bidder, the Town of Gordonsville decided it was in its best interest to re-advertise and receive bids for the project. The requested increase is for the state share of the new bid amount over the existing CAF grant (CA9070-07).

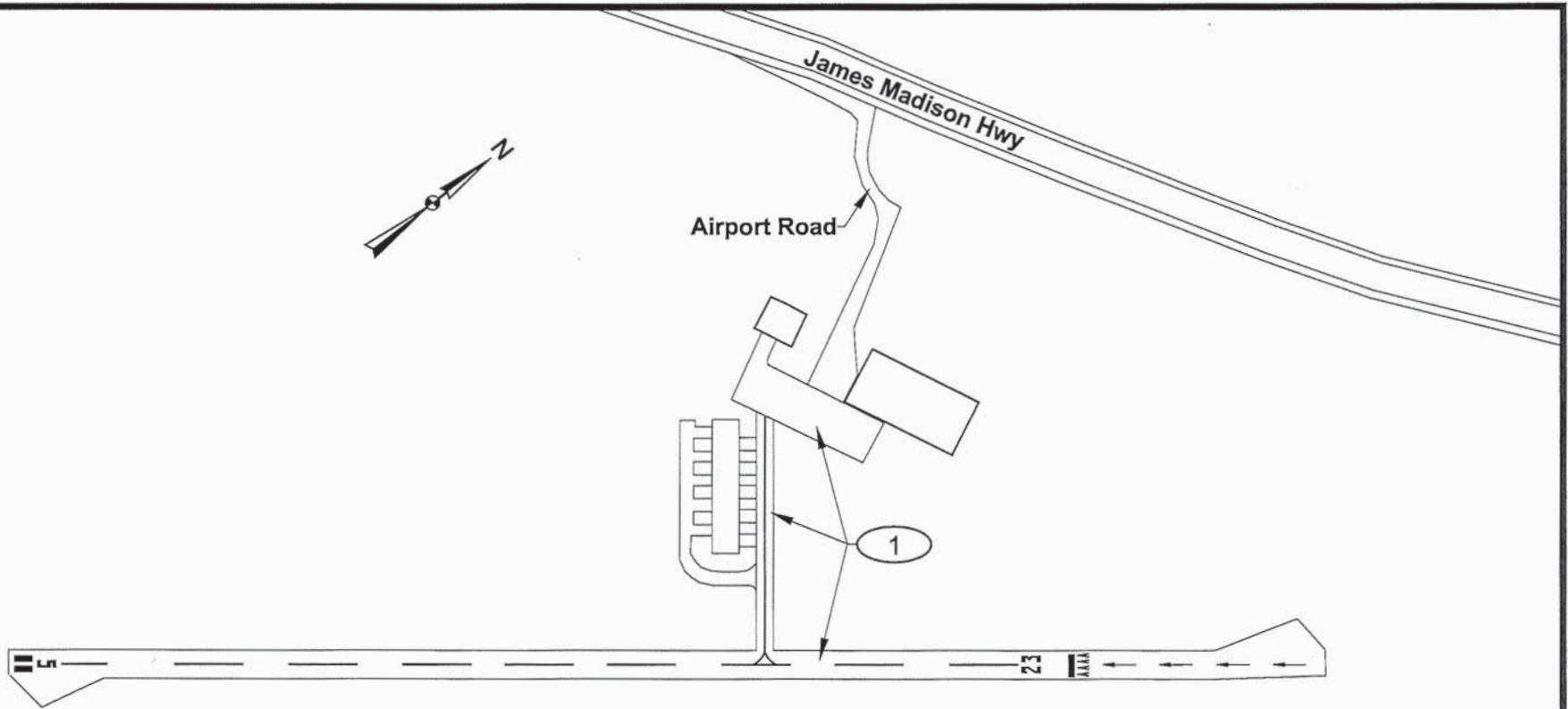

1 REHABILITATE RUNWAY, TAXIWAY & APRON

ACIP SKETCH

GORDONSVILLE MUNICIPAL AIRPORT

TALBERT & BRIGHT

ENGINEERING & PLANNING CONSULTANTS
 10105 KRAUSE ROAD, SUITE 100
 CHESTERFIELD, VIRGINIA 23832
 PHONE: 804-768-6878 FAX: 804-768-6871

AIR CARRIER / RELIEVER AIRPORTS - DISCRETIONARY FUNDS
RECOMMENDED PROJECTS

FUNDED

PRIORITY NO.	AIRPORT NAME	DESCRIPTION	FEDERAL AMOUNT	STATE DISCR. AMOUNT	LOCAL AMOUNT	TOTAL PROJECT AMOUNT
184	Stafford Regional Airport	Runway 15 Extension - Phase 2 (AIP) - CHANGE ORDER	\$916,875.00	\$81,500.00	\$20,375.00	\$1,018,750.00
153	Stafford Regional Airport	Fueling System Upgrade - Reclaimed Fuel Vessels (Construction)	\$0.00	\$1,511.00	\$3,069.16	\$4,580.16
121	Leesburg Executive Airport	Hangars A, B, C & D Taxilanes Rehabilitation (Design)	\$0.00	\$104,000.00	\$26,000.00	\$130,000.00
110	Stafford Regional Airport	T-Hangars 6, 7 & 8 Site Preparation (Design)	\$0.00	\$136,000.00	\$34,000.00	\$170,000.00
85	Culpeper Regional Airport	East Side Terminal Area Plan	\$0.00	\$82,937.00	\$20,735.00	\$103,672.00
REGION TOTALS:			\$916,875.00	\$405,948.00	\$104,179.16	\$1,427,002.16

COMMONWEALTH AVIATION FUND
 FUNDING REQUEST SUMMARY
 VAB DATE: 05/25/2022

Airport: Culpeper Regional Airport
 Region: 3
 Name: Mr. Derek "Dak" Hardwick

Sponsor: County of Culpeper
 Contact: Mr. John Egertson , County Administrator
 Phone: 540-727-3404

State Funding Summary		
	Requested	Recommended
Entitlement	\$0.00	\$0.00
Air Carrier/Reliever Discretionary	\$82,937.00	\$82,937.00
General Aviation Discretionary	\$0.00	\$0.00
TOTALS	\$82,937.00	\$82,937.00

Unmitigated Obstructions

Based Aircraft:	154
Annual Operations:	60,943
Service Role:	RL

Development Program Projects									
Projects			Requested Funding			Recommended Funding			
Description	Priority	Project Cost	Federal	State	Local	Federal	State	Local	
East Side Terminal Area Plan	85	\$103,672.00	\$0.00	\$82,937.00	\$20,735.00	\$0.00	\$82,937.00	\$20,735.00	
TOTALS		\$103,672.00	\$0.00	\$82,937.00	\$20,735.00	\$0.00	\$82,937.00	\$20,735.00	

Remarks: East Side Terminal Area Plan
 Staff recommends approval.

Culpeper Regional Airport East Side Terminal Area Plan Project Narrative

During the development of the Greenhouse Road Extension, the airport, county, Virginia Department of Aviation (DOAV), and Federal Aviation Administration (FAA) all extensively discussed the need to access the east side of Culpeper Regional Airport for the purposes of economic and infrastructure development. As a result of this, the Virginia Department of Aviation requested the county prepare a terminal area plan (TAP) focusing on the east side development to evaluate development needs and update the ALP.

The attached scope of work and manhour estimate is to provide Culpeper County with a terminal area plan that evaluates the facility requirements on the east side of the airport, updates the layout to reflect changes in facility requirements, and updates the phasing and costs associated with those improvements. Tasks include:

- Inventory
- Abbreviated forecast (analyzing current FAA TAF data and comparing to actual based aircraft and waiting lists)
- Facility requirements for the east side
- Alternative development plans
- Environmental cost analysis
- Update airport layout plan sheet 3
- Show phasing for improvements and estimate costs
- Provide reports
- Respond to comments

Additionally, in direct response to DOAV questions during the grant application process for the *Greenhouse Road Extension*, in July 2021 Culpeper County prepared the East Side Development – Phase 1 15% Design Drawings. This project analyzed the projected (from the most recent master plan) vs. the current actual need for T-hangars based on current occupancy and waiting lists. The project also provided +/- 15% design drawings for the phase 1 T-hangar project. These drawings refined the layout beyond what was shown on the airport layout plan in order to optimize T-hangar space and available geometry. Also, the preliminary design provided a cost estimate commensurate with the 15% design drawings and associated quantity takeoff. The project developed two options, one with the hangars oriented parallel to the runway and one with the hangars oriented perpendicular, with cost estimated and estimated funding levels for both. This project is also part of this grant request and the work done on this project will be incorporated into the TAP.

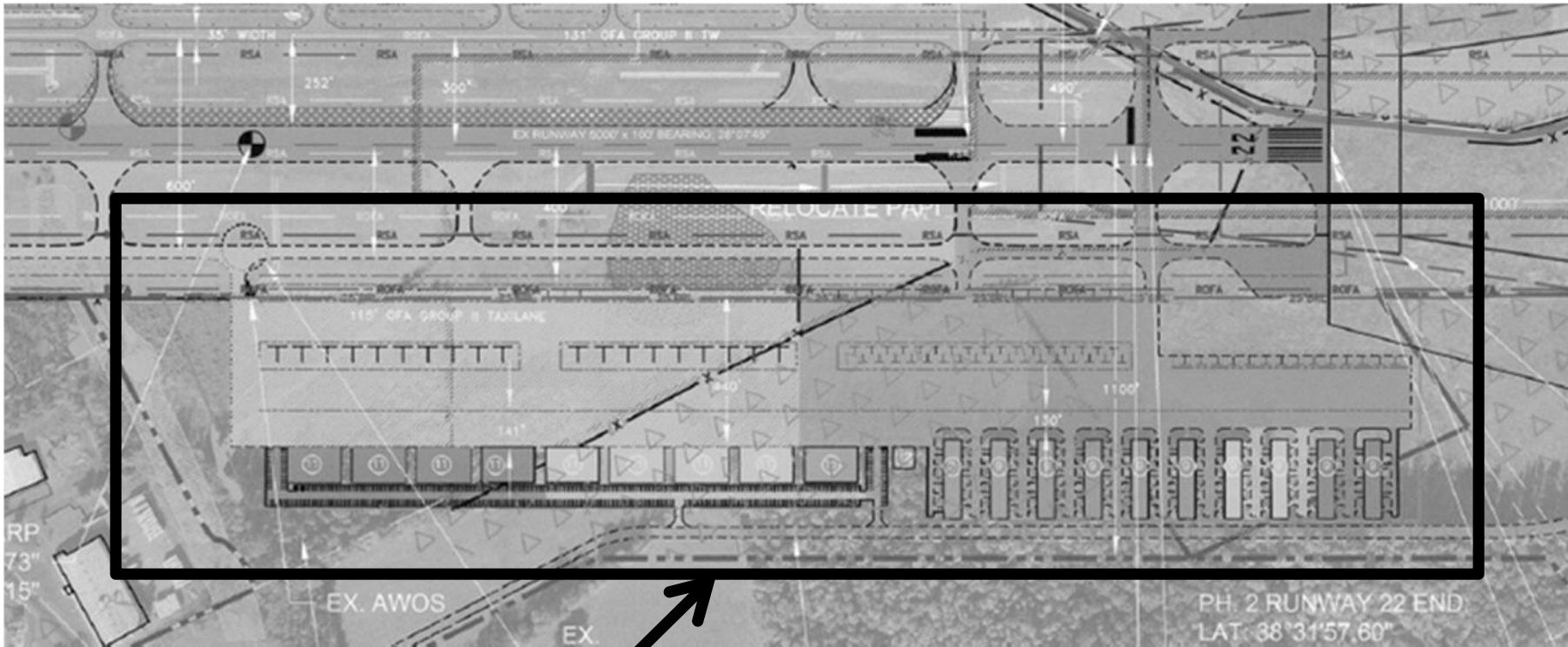

Approximate study area

North (approximate)

COMMONWEALTH AVIATION FUND
 FUNDING REQUEST SUMMARY
 VAB DATE: 05/25/2022

Airport: Leesburg Executive Airport
 Region: 3
 Name: Mr. Derek "Dak" Hardwick

Sponsor: Town of Leesburg
 Contact: Mr. Kaj Dentler , Deputy Town Manager
 Phone: 703-771-2710

State Funding Summary		
	Requested	Recommended
Entitlement	\$0.00	\$0.00
Air Carrier/Reliever Discretionary	\$104,000.00	\$104,000.00
General Aviation Discretionary	\$0.00	\$0.00
TOTALS	\$104,000.00	\$104,000.00

Unmitigated Obstructions

Based Aircraft:	245
Annual Operations:	105,792
Service Role:	RL

Development Program Projects									
Projects			Requested Funding			Recommended Funding			
Description	Priority	Project Cost	Federal	State	Local	Federal	State	Local	
Hangars A, B, C & D Taxilanes Rehabilitation (Design)	121	\$130,000.00		\$104,000.00	\$26,000.00		\$104,000.00	\$26,000.00	
TOTALS		\$130,000.00	\$0.00	\$104,000.00	\$26,000.00	\$0.00	\$104,000.00	\$26,000.00	

Remarks: Hangars A, B, C & D Taxilanes Rehabilitation (Design)
 Staff recommends approval.

**AIRPORT CAPITAL IMPROVEMENT PROGRAM
PROJECT NARRATIVE
LEESBURG EXECUTIVE AIRPORT (JYO)**

The following program narrative addresses the project description and justification for the current year of the Airport Capital Improvement Program.

1 Hangars A, B, C & D Pavement Rehabilitation (Design)

This scope includes the preparation of site construction documents for the rehabilitation of the existing T-hangar pavements between Hangars A, B, C, & D and the existing parking lot for Hangar D at the Leesburg Executive Airport. These pavements have PCI ratings from 14 (Serious) to 48 (Poor) based on the most recent pavement study.

The project budget includes a Sponsor Administrative Costs allowance for incidental costs that may be incurred.

This request is for the state 80% share of the project.

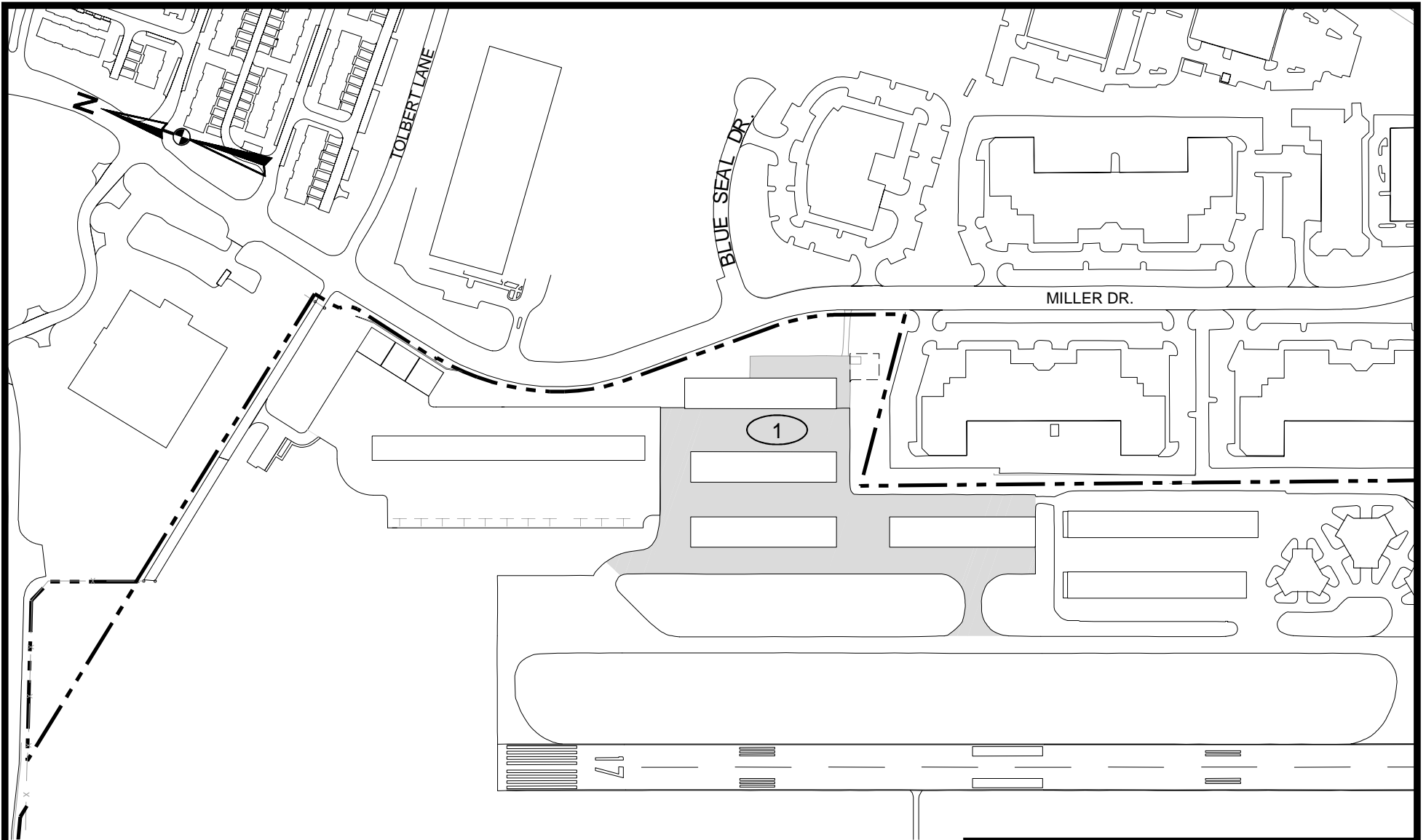

① HANGARS A, B, C & D PAVEMENT REHABILITATION (DESIGN)

ACIP SKETCH
LEESBURG EXECUTIVE AIRPORT
TALBERT & BRIGHT ENGINEERING & PLANNING CONSULTANTS 10105 KRAUSE ROAD, SUITE 100 CHESTERFIELD, VIRGINIA 23832 PHONE: 804-768-6878 FAX: 804-768-6871

COMMONWEALTH AVIATION FUND
FUNDING REQUEST SUMMARY
VAB DATE: 05/25/2022

Airport: Stafford Regional Airport
Region: 3
Name: Mr. Derek "Dak" Hardwick

Sponsor: Stafford Regional Airport Authority
Contact: Mr. Samer Shalaby , Chairman
Phone: 540-452-1304

State Funding Summary		
	Requested	Recommended
Entitlement	\$0.00	\$0.00
Air Carrier/Reliever Discretionary	\$219,011.00	\$219,011.00
General Aviation Discretionary	\$0.00	\$0.00
TOTALS	\$219,011.00	\$219,011.00

Unmitigated Obstructions

Based Aircraft:	67
Annual Operations:	33,675
Service Role:	RL

Development Program Projects								
Description	Priority	Project Cost	Requested Funding			Recommended Funding		
			Federal	State	Local	Federal	State	Local
Fueling System Upgrade - Reclaimed Fuel Vessels (Construction)	153	\$4,580.16		\$1,511.00	\$3,069.16		\$1,511.00	\$3,069.16
Runway 15 Extension - Phase 2 (AIP) - CHANGE ORDER	184	\$1,018,750.00	\$916,875.00	\$81,500.00	\$20,375.00	\$916,875.00	\$81,500.00	\$20,375.00
T-Hangars 6, 7 & 8 Site Preparation (Design)	110	\$170,000.00		\$136,000.00	\$34,000.00		\$136,000.00	\$34,000.00
TOTALS		\$1,193,330.16	\$916,875.00	\$219,011.00	\$57,444.16	\$916,875.00	\$219,011.00	\$57,444.16

Remarks: Fueling System Upgrade - Reclaimed Fuel Vessels (Construction)

Staff recommends approval.

Runway 15 Extension - Phase 2 (AIP) - CHANGE ORDER

Staff recommends approval upon an exception to VAB policy.

VAB policy does not allow funding of construction work already performed. As the runway project was funded with a 100 percent federal CARES Act grant, no state funding was utilized for the eligible project. CARES Act grants have no allowance for project overruns/change orders, so the FAA will be offering a 90 percent AIP grant to cover this cost increase. In an effort to maximize federal funding and assist the sponsor with normally eligible costs, DOAV staff recommends a one-time exception to VAB policy in this situation.

T-Hangars 6, 7 & 8 Site Preparation (Design)

Staff recommends approval.

**AIRPORT CAPITAL IMPROVEMENT PROGRAM
PROJECT NARRATIVE
STAFFORD REGIONAL AIRPORT (RMN)**

Fuel Recovery System

Stafford Regional Airport operates a fuel farm with two 12,000 gallons storage tanks and two refueling trucks for servicing aircraft. Both the tanks and the trucks require a daily draining of fuel samples to detect and capture contaminants that may be present in the fuel. The number of sampling points and quantity of drained fuel required at each point over time results in a cost that is not insignificant. Further, the drained fuel must be disposed of rather than returned to the tanks, adding the cost equation.

The installation of the recovery system provided for in the estimate is non-electrical and is able to recapture and return the usable part of the sampled fuel to the tanks, resulting in a cost savings to the airport from both fuel sales and a significantly reduced cost to properly dispose of the unusable fuel. Consultations with both knowledgeable FBO personnel and the manufacturer's technical representative, who is also the designer of the system, confirms that the systems bid will accomplish the above desired results in the most effective manner. All fittings and lines are included in the shipped unit.



REVISIONS			
REV	DESCRIPTION	DATE	APPROVED

Submittal Datasheet for Sump Fuel Recovery System

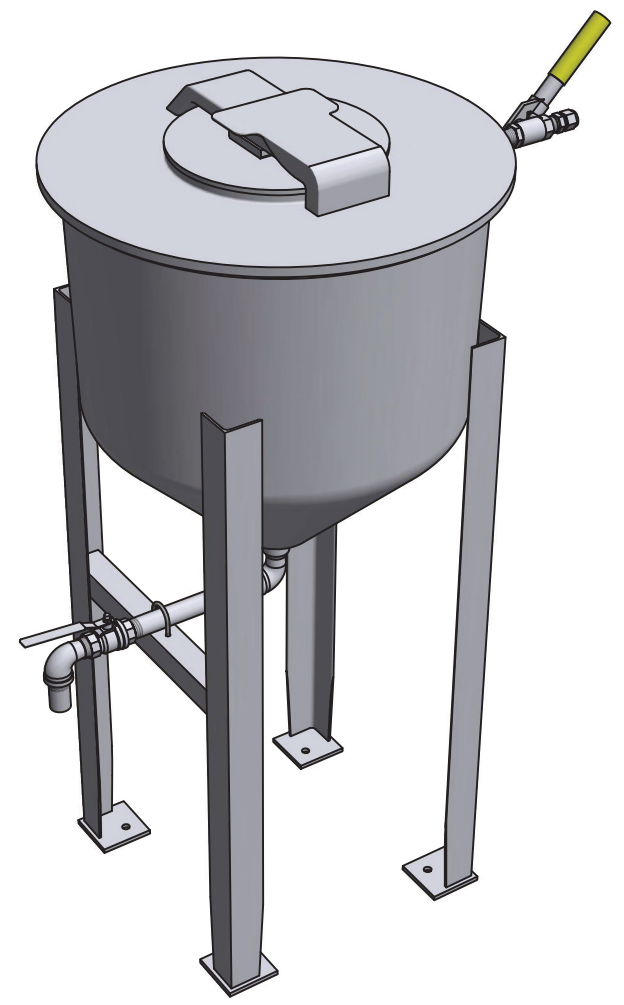
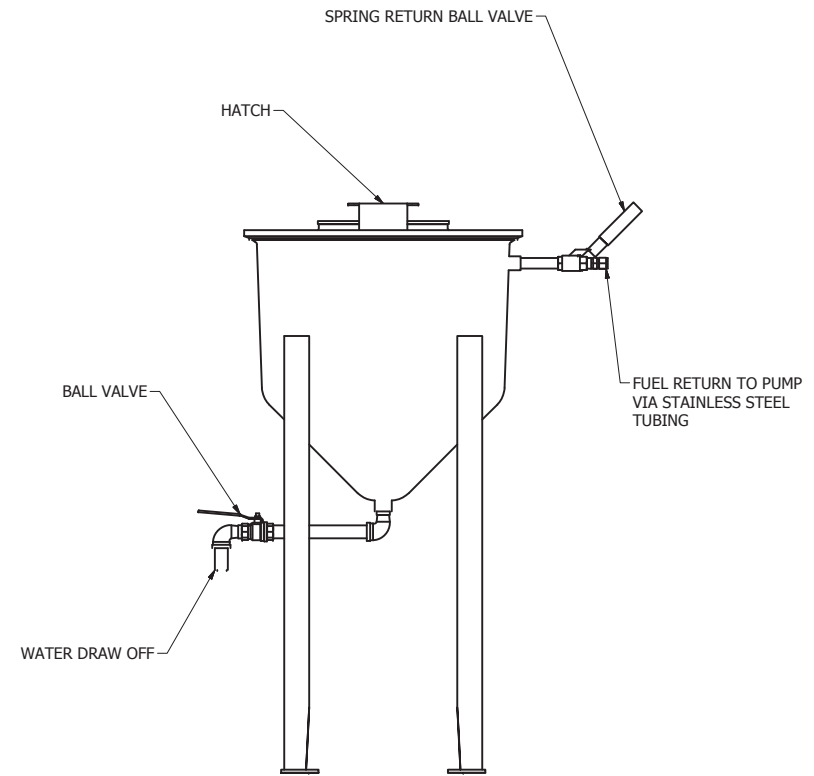
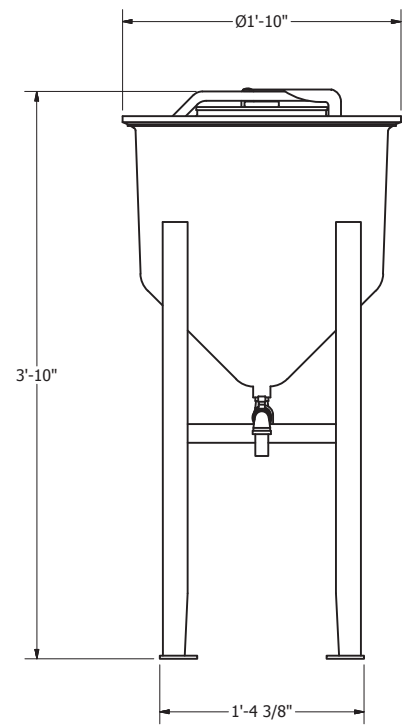
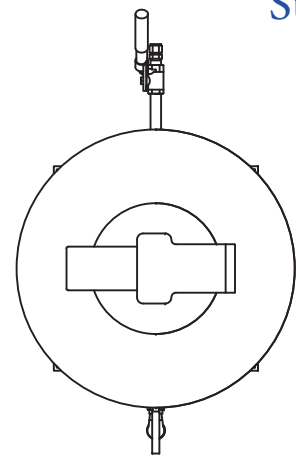

COPYRIGHT FUELTECH, INC. 2016
 THIS DRAWING IS THE PROPERTY OF FUEL TECH INC.,
 AND MAY NOT BE REPRODUCED IN ANY MANNER
 WITHOUT WRITTEN CONSENT OF FUELTECH, INC.
 VAB Package May 2022
 DIMENSIONS SHOWN ARE NOMINAL DIMENSIONS FOR
 INFORMATIONAL PURPOSES ONLY, UNLESS SPECIFIC
 MANUFACTURING TOLERANCES ARE SPECIFIED.
 DO NOT SCALE DRAWINGS

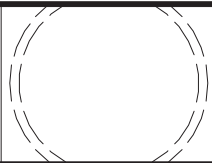

Fuel Tech Inc

P.O. Box 1079 2680 US 1
 Mims, FL 32754 1-800-628-1863
 PCC 1256831 www.fueltech.com

JOB NUMBER: TITLE:
 FILE NAME: SUMP.dwg
 DATE: 01/18/16
 DRAWN: JLP OWNER:

20 GAL SUMP RECOVERY UNIT
 100

FUEL TECH INC. DRAWING NO. REV

**AIRPORT CAPITAL IMPROVEMENT PROGRAM
PROJECT NARRATIVE
STAFFORD REGIONAL AIRPORT (RMN)**

The following project narrative addresses the project description and justification for the current year of the Airport Capital Improvement Program.

1 T-Hangars 6, 7 & 8 Site Preparation (Design)

Increased growth and activity has the airport with an immediate need for additional hangar space. The Airport currently has more than 20 potential tenants on the waiting list. This project is for preparation of site construction documents for the construction of 3 new hangar sites to the north of existing T-Hangar No. 5 (approximately 10 acres). These sites have already been cleared environmentally and received a FONSI (Finding of No Significant Impact) as part of the Environmental Assessment that was conducted for the runway extension and future development. In addition, this scope includes the design of an access road, auto parking and connector taxiway to the existing parallel taxiway.

The project budget includes a Sponsor Administrative Cost allowance for plan review fees, advertisement, shipping and other incidental costs that may be incurred.

This request is for the state 80% share of the project.

2 Runway 15 Extension Phase II Change Order (Blasting)

In June 2021, during Phase I mass grading operation, the Phase I contractor encountered sandstone. During the initial design, and based on geotechnical consultation, it was anticipated that higher blow count materials would be “rippable”. The Phase II contractor, Chemung Contracting, encountered more of the same material during grading operations. Chemung made several attempts to shear the rock using a bulldozer and excavator but has been unsuccessful. Although rock was encountered in Phase I, it did not occur until after the Phase II project had been bid.

On January 31, 2022, Chemung submitted an RFI requesting direction on the removal of the material. The contractor was requested to provide a unit cost for blasting the material consistent meeting FAA AC 150/5370-10H Section 70-09 Use of Explosives and Project Specification 152-2.a. Blasting.

A formal proposal was submitted to the Engineer (Talbert & Bright) on February 7, 2022. The proposal included a mass blasting unit cost of \$13.85 per CY for a total cost of \$969,500.00 and a trench blasting unit cost of \$49.25 per cubic yard for a total of \$49,250.00. The total cost of the proposal is \$1,018,750. The final quantity of blasting will be tracked by the resident project representative and confirmed for final payment.

This request is for the state 8% match to the AIP funding for the additional work.

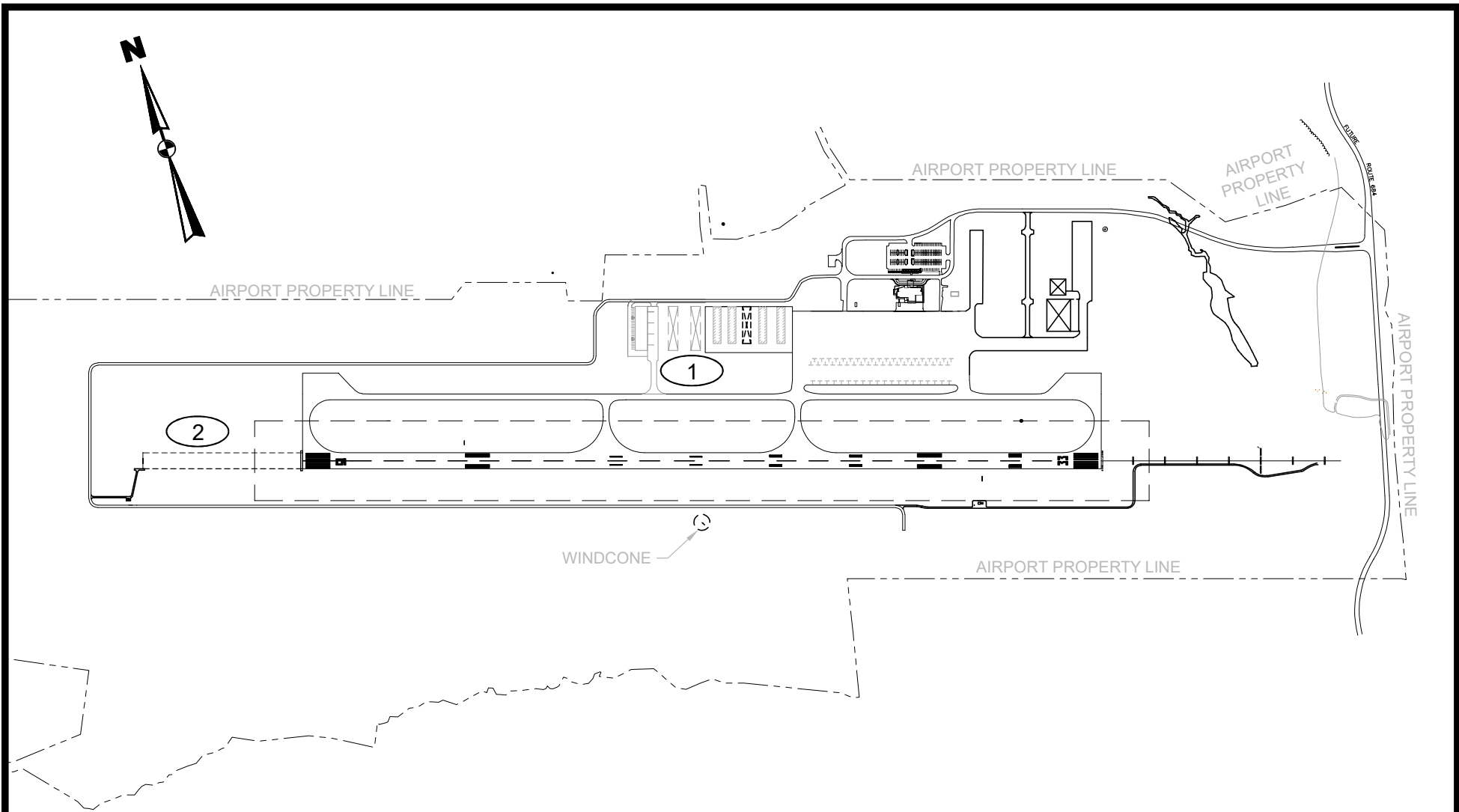

- ① T-HANGARS 6, 7, & 8 SITE PREPARATION (DESIGN)
- ② RUNWAY 15 EXTENSION PHASE II CHANGE ORDER (BLASTING)

ACIP SKETCH
STAFFORD REGIONAL AIRPORT
TALBERT & BRIGHT ENGINEERING & PLANNING CONSULTANTS 10105 KRAUSE ROAD, SUITE 100 CHESTERFIELD, VIRGINIA 23832 PHONE: 804-768-6878 FAX: 804-768-6871

COMMERCIAL AIRPORTS - ENTITLEMENT FUND
RECOMMENDED PROJECTS

FUNDED

PRIORITY NO.	AIRPORT NAME	DESCRIPTION	FEDERAL AMOUNT	STATE ENTITL. AMOUNT	STATE DISCR. AMOUNT	LOCAL AMOUNT	TOTAL PROJECT AMOUNT
193	Richmond International Airport	Federal Inspection Service Facility Renovation (Construction)	\$3,969,000.00	\$50,467.36	\$302,332.64	\$2,978,200.00	\$7,300,000.00

FUNDING TOTALS:	\$3,969,000.00	\$50,467.36	\$302,332.64	\$2,978,200.00	\$7,300,000.00
-----------------	----------------	-------------	--------------	----------------	----------------

TOTAL ALLOCATION OF STATE ENTITLEMENT FUNDS: \$50,467.36
 ADDITIONAL DISCRETIONARY REQUESTED: \$302,332.64

SUMMARY FUNDING TOTALS:	\$3,969,000.00	\$50,467.36	\$302,332.64	\$2,978,200.00	\$7,300,000.00
-------------------------	----------------	-------------	--------------	----------------	----------------

AIR CARRIER / RELIEVER AIRPORTS - DISCRETIONARY FUNDS
RECOMMENDED PROJECTS

FUNDED

PRIORITY NO.	AIRPORT NAME	DESCRIPTION	FEDERAL AMOUNT	STATE DISCR. AMOUNT	LOCAL AMOUNT	TOTAL PROJECT AMOUNT
193	Richmond International Airport	Federal Inspection Service Facility Renovation (Construction)	\$3,969,000.00	\$302,332.64	\$2,978,200.00	\$7,300,000.00
186	Hanover County Municipal Airport	West Apron Rehabilitation - Phase 1 (Construction)	\$0.00	\$120,000.00	\$30,000.00	\$150,000.00
162	Tappahannock-Essex County Airport	Rotating Beacon Replacement	\$0.00	\$13,584.00	\$3,396.00	\$16,980.00
143	Tappahannock-Essex County Airport	Terminal Building HVAC Replacement (Construction)	\$0.00	\$23,160.00	\$5,790.00	\$28,950.00
125	Louisa County Airport	South Side Taxiway (Design)	\$184,500.00	\$16,400.00	\$4,100.00	\$205,000.00
REGION TOTALS:			\$4,153,500.00	\$475,476.64	\$3,021,486.00	\$7,700,930.00

COMMONWEALTH AVIATION FUND
 FUNDING REQUEST SUMMARY
 VAB DATE: 05/25/2022

Airport: Hanover County Municipal Airport
 Region: 4
 Name: Mr. Alan Abbott

Sponsor: County of Hanover
 Contact: Mr. Mike Flagg , Director of Public Works
 Phone: 840-365-6182

State Funding Summary		
	Requested	Recommended
Entitlement	\$0.00	\$0.00
Air Carrier/Reliever Discretionary	\$120,000.00	\$120,000.00
General Aviation Discretionary	\$0.00	\$0.00
TOTALS	\$120,000.00	\$120,000.00

Unmitigated Obstructions

Based Aircraft:	110
Annual Operations:	37,729
Service Role:	RL

Development Program Projects									
Description	Priority	Project Cost	Federal	Requested Funding			Recommended Funding		
				State	Local	Federal	State	Local	
West Apron Rehabilitation - Phase 1 (Construction)	186	\$150,000.00		\$120,000.00	\$30,000.00		\$120,000.00	\$30,000.00	
TOTALS		\$150,000.00	\$0.00	\$120,000.00	\$30,000.00	\$0.00	\$120,000.00	\$30,000.00	

Remarks: West Apron Rehabilitation - Phase 1 (Construction)
 Staff recommends approval.

Hanover County Municipal Airport

Project Narrative

Westside Ramp Apron Milling/Overlay

Background: Portions of the Westside Terminal Ramp ramp/pavement are nearing the end of their useful life. The most recent DOAV Pavement Condition Study has indicated Pavement Condition Indexes in areas of the apron identified as serious, poor, and fair (see attachment A). The intent of this project will be to mill and overlay part of the most critical areas as identified in the field and depicted in the Drawing (see attachment B), using local and state funding. The strategy is to replace the center, most used portion of the apron.

Procurement and Asphalt type: Accomplish 12,000 sq. yards of milling and replacement of top 2 inches utilizing the county's annual contractor and a state mix. There will be some miscellaneous striping and some asphalt handwork around the tie downs that have not been included in the estimate yet. The Airport hopes to do the work during the summer of 2022.

Future initiatives: This will repair approximately 1/3 of the apron surface in the most critical area. Future request are anticipated pending available funding in future years.



COMMONWEALTH AVIATION FUND
 FUNDING REQUEST SUMMARY
 VAB DATE: 05/25/2022

Airport: Louisa County Airport
 Region: 4
 Name: Mr. Alan Abbott

Sponsor: Industrial Development Authority of Louisa County
 Contact: Mr. Willie Harper , Chairman
 Phone:

State Funding Summary		
	Requested	Recommended
Entitlement	\$0.00	\$0.00
Air Carrier/Reliever Discretionary	\$16,400.00	\$16,400.00
General Aviation Discretionary	\$0.00	\$0.00
TOTALS	\$16,400.00	\$16,400.00

Unmitigated Obstructions

Based Aircraft:	55
Annual Operations:	24,285
Service Role:	RL

Development Program Projects									
Description	Priority	Project Cost	Requested Funding			Recommended Funding			Local
			Federal	State	Local	Federal	State		
South Side Taxiway (Design)	125	\$205,000.00	\$184,500.00	\$16,400.00	\$4,100.00	\$184,500.00	\$16,400.00	\$4,100.00	
TOTALS		\$205,000.00	\$184,500.00	\$16,400.00	\$4,100.00	\$184,500.00	\$16,400.00	\$4,100.00	

Remarks: South Side Taxiway (Design)
 Staff recommends approval.

**AIRPORT CAPITAL IMPROVEMENT PROGRAM
PROGRAM NARRATIVE
LOUISA COUNTY AIRPORT (LKU)**

The following program narrative addresses the detailed project description and justification for the current year of the Airport Capital Improvement Program.

1 South Side Development - Phase 1 (Taxiway) (Design)

The Airport is moving forward with the development on the south side of the runway. This first phase includes the design and bidding phases for the connector and partial parallel taxiway to serve the future development as depicted on the airport's current approved ALP.

The project budget includes an allowance for Sponsor Administrative Costs for shipping and other incidental costs that may be incurred.

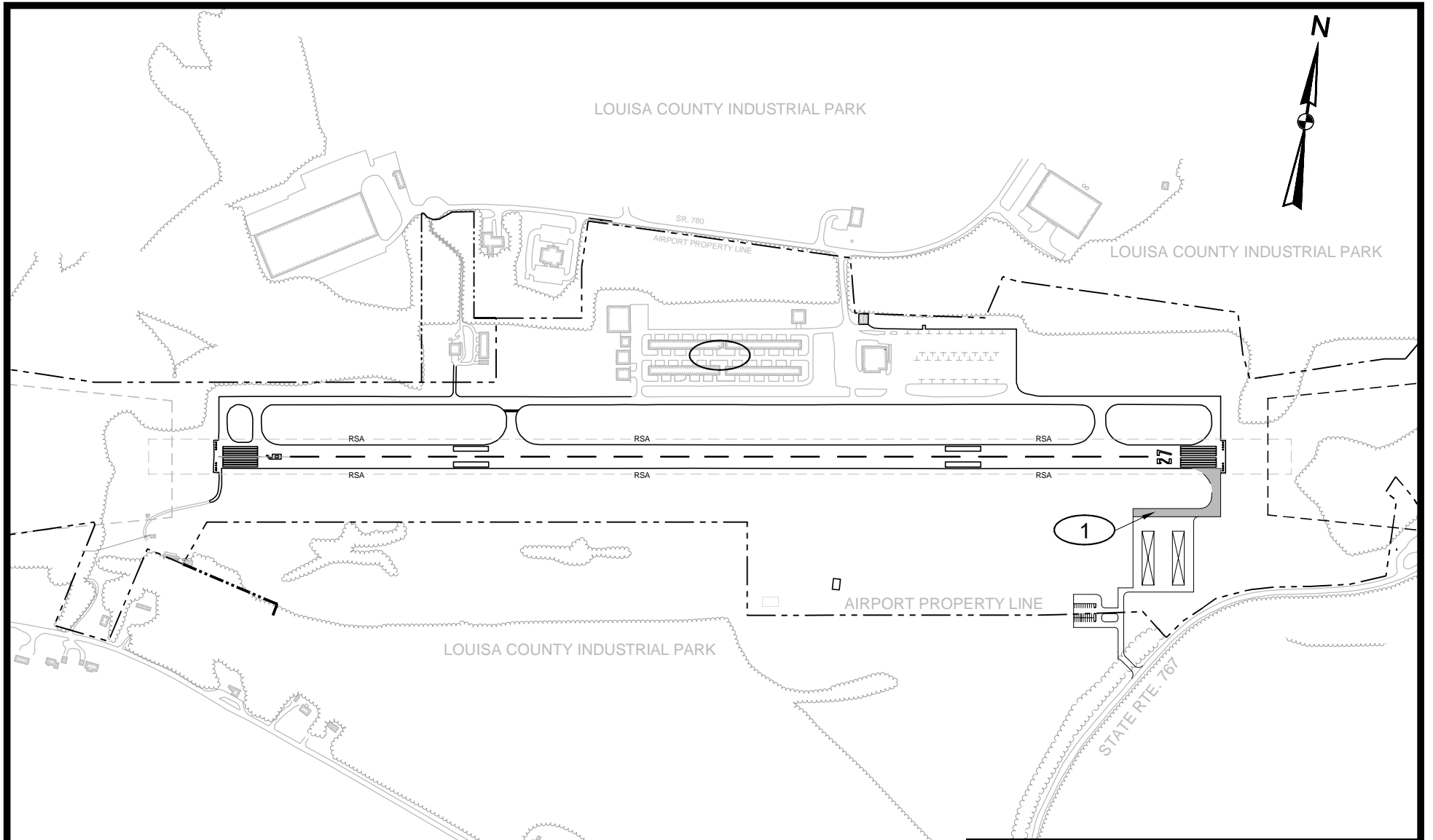

1

SOUTHSIDE DEVELOPMENT- PHASE I (TAXIWAY) (DESIGN)

ACIP SKETCH
LOUISA COUNTY AIRPORT
TALBERT & BRIGHT ENGINEERING & PLANNING CONSULTANTS 10105 KRALUSE ROAD, SUITE 100 CHESTERFIELD, VIRGINIA 23832 PHONE: 804-768-6878 FAX: 804-768-6871

COMMONWEALTH AVIATION FUND
 FUNDING REQUEST SUMMARY
 VAB DATE: 05/25/2022

Airport: Richmond International Airport
 Region: 4
 Name: Mr. Alan Abbott

Sponsor: Capital Region Airport Commission
 Contact: Mr. John Rutledge , Director, Engineering & Planning
 Phone: 804-226-3019

State Funding Summary		
	Requested	Recommended
Entitlement	\$50,467.00	\$50,467.36
Air Carrier/Reliever Discretionary	\$302,333.00	\$302,332.64
General Aviation Discretionary	\$0.00	\$0.00
TOTALS	\$352,800.00	\$352,800.00

Unmitigated Obstructions

Based Aircraft:	62
Annual Operations:	102,845
Service Role:	CS

Development Program Projects									
Projects			Requested Funding			Recommended Funding			
Description	Priority	Project Cost	Federal	State	Local	Federal	State	Local	
Federal Inspection Service Facility Renovation (Construction)	193	\$7,300,000.00	\$3,969,000.00	\$352,800.00	\$2,978,200.00	\$3,969,000.00	\$352,800.00	\$2,978,200.00	
TOTALS		\$7,300,000.00	\$3,969,000.00	\$352,800.00	\$2,978,200.00	\$3,969,000.00	\$352,800.00	\$2,978,200.00	

Remarks: Federal Inspection Service Facility Renovation (Construction)
 Staff recommends approval.

**Richmond International Airport
Project Narrative
May 2022 VAB Meeting**

FIS (Customs) Renovations Narrative

Renovation of the existing Federal Inspection Station Facility at the Richmond International Airport to meet current Customs and Border Protection standards. Work will include modifications to the mechanical, electrical, plumbing, electronic and telecommunications systems. Renovation of the FIS will require relocation of an existing baggage handling system and full replacement of another unit. Site work will include modifications to existing sidewalks, installation of new standing seam canopy on the inbound bag belt and modifications to pavement striping.

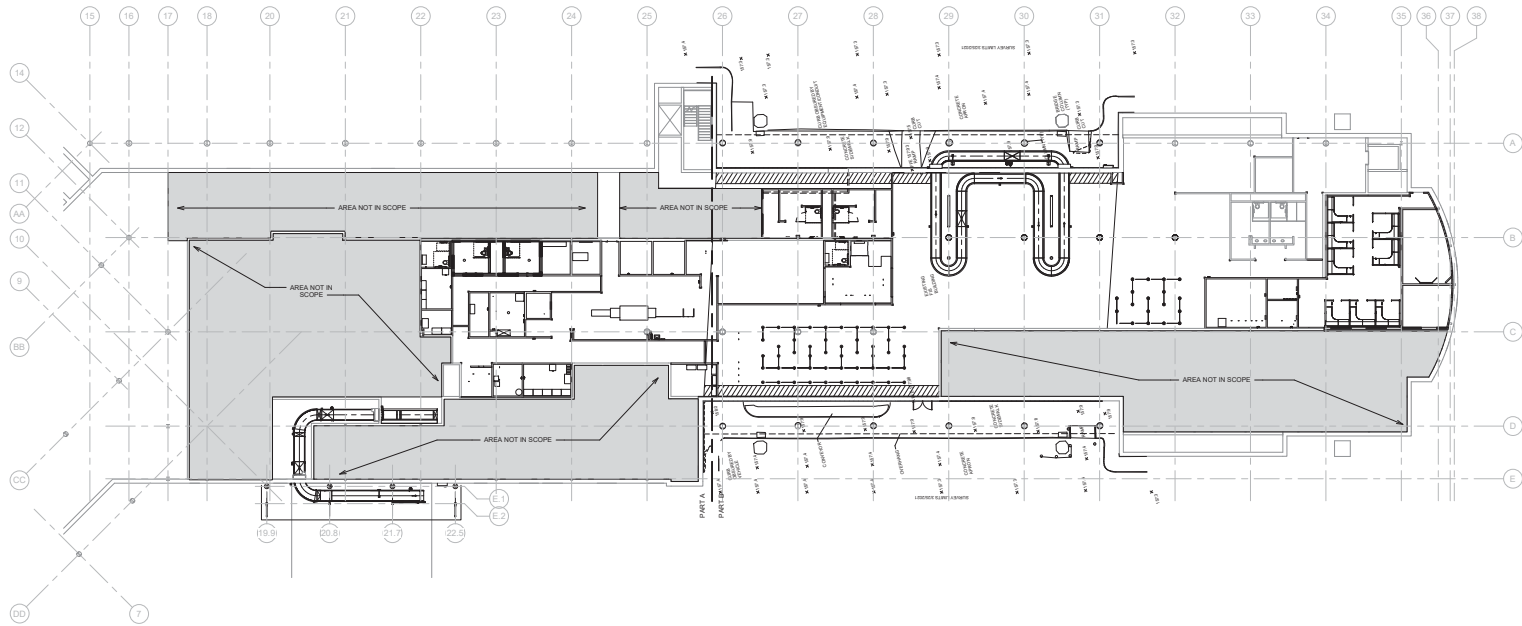

1 ARCHITECTURAL SITE PLAN
1/16" = 1'-0"

**NOT FOR
CONSTRUCTION**

Revision		
No.	Date	Description

COMMONWEALTH AVIATION FUND
FUNDING REQUEST SUMMARY
VAB DATE: 05/25/2022

Airport: Tappahannock-Essex County Airport
Region: 4
Name: Mr. Alan Abbott

Sponsor: Essex County Airport Authority
Contact: Mr. Barry Bates Jr., Chairman
Phone:

State Funding Summary		
	Requested	Recommended
Entitlement	\$0.00	\$0.00
Air Carrier/Reliever Discretionary	\$36,744.00	\$36,744.00
General Aviation Discretionary	\$0.00	\$0.00
TOTALS	\$36,744.00	\$36,744.00

Unmitigated Obstructions

Based Aircraft:	31
Annual Operations:	16,556
Service Role:	RL

Development Program Projects									
Description	Priority	Project Cost	Federal	Requested Funding			Recommended Funding		
				State	Local	Federal	State	Local	
Rotating Beacon Replacement	162	\$16,980.00		\$13,584.00	\$3,396.00		\$13,584.00	\$3,396.00	
Terminal Building HVAC Replacement (Construction)	143	\$28,950.00		\$23,160.00	\$5,790.00		\$23,160.00	\$5,790.00	
TOTALS		\$45,930.00	\$0.00	\$36,744.00	\$9,186.00	\$0.00	\$36,744.00	\$9,186.00	

Remarks: Rotating Beacon Replacement

Staff recommends approval.

Terminal Building HVAC Replacement (Construction)

Staff recommends approval.

**AIRPORT CAPITAL IMPROVEMENT PROGRAM
PROJECT NARRATIVE
TAPPAHANNOCK-ESSEX COUNTY AIRPORT (XSA)**

The following program narrative addresses the project description and justification for the current year of the Airport Capital Improvement Program.

1 Rotating Beacon - LED

This existing rotating beacon has not been functioning properly and requires frequent service. Because of the age of the beacon, it's difficult to find parts and parts and maintenance are becoming more expensive. The airport's NAVAIDs and lighting consultant has recommended that the unit be replaced with a new LED beacon. The new beacon will be more energy efficient and less costly to operate.

2 HVAC Repairs

The HVAC system is the original one that was installed when the terminal was built and has outlived its useful life. This project is to replace the existing 12-ton heat pump system with a more efficient 14-ton heat pump system along with a 20KW heater pack and thermostat. Duct work will be modified and adjusted to fit the new system and everything will be re-wired.

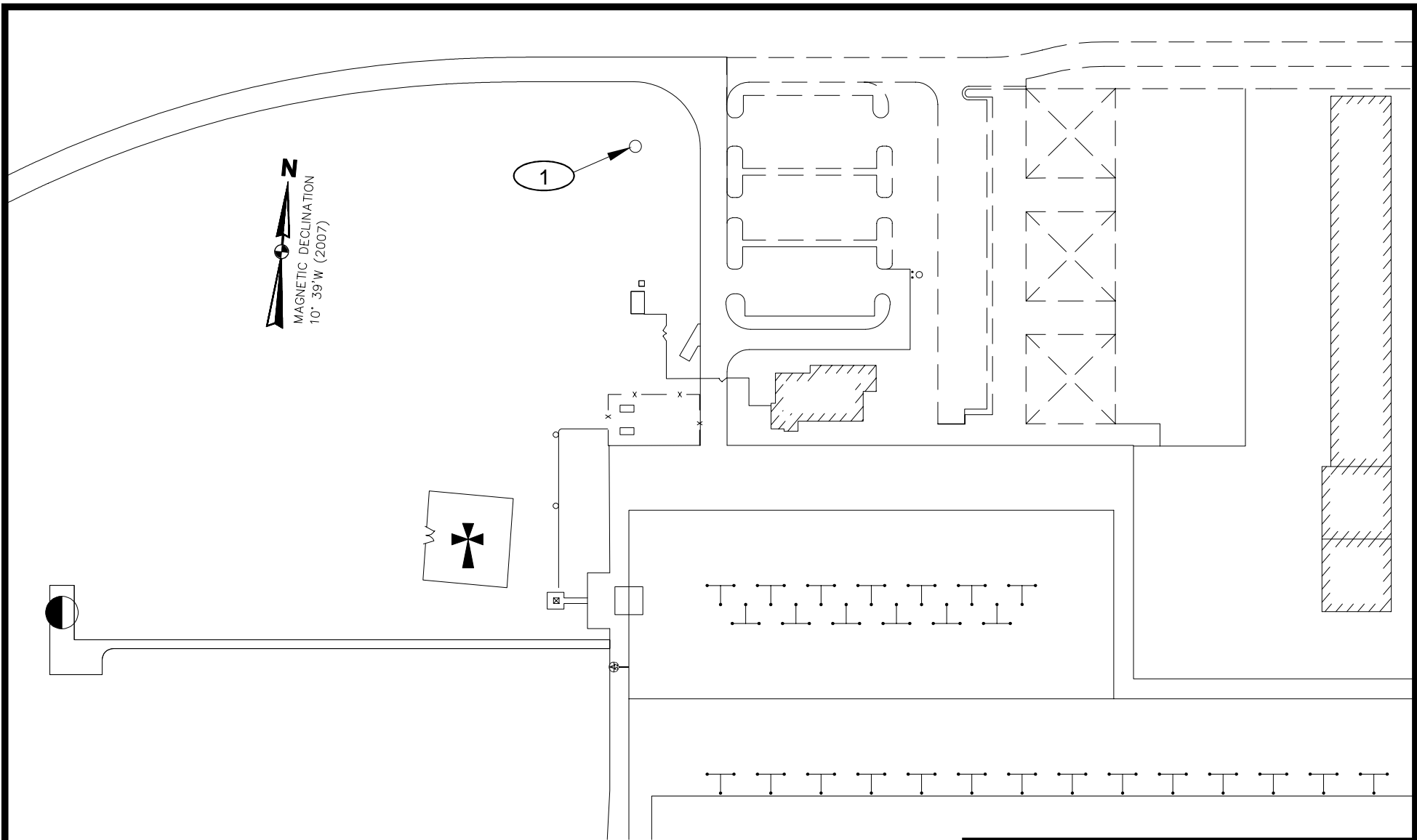

1 ROTATING BEACON REPLACEMENT

ACIP SKETCH
TAPPAHANNOCK-ESSEX COUNTY AIRPORT
TALBERT & BRIGHT ENGINEERING & PLANNING CONSULTANTS 10105 KRAUSE ROAD, SUITE 100 CHESTERFIELD, VIRGINIA 23832 PHONE: 804-768-6878 FAX: 804-768-6871

This page intentionally left blank.

Virginia Aviation Board
May 25, 2022 Meeting

No requests were received for Region 5.

This page intentionally left blank.

AIR CARRIER / RELIEVER AIRPORTS - DISCRETIONARY FUNDS
RECOMMENDED PROJECTS

FUNDED

PRIORITY NO.	AIRPORT NAME	DESCRIPTION	FEDERAL AMOUNT	STATE DISCR. AMOUNT	LOCAL AMOUNT	TOTAL PROJECT AMOUNT
187	Lake Country Regional Airport	East and West Side Runway Obstruction Survey and Removal	\$0.00	\$10,240.00	\$2,560.00	\$12,800.00
147	Lake Country Regional Airport	Security Camera System	\$0.00	\$3,240.00	\$360.00	\$3,600.00
REGION TOTALS:			\$0.00	\$13,480.00	\$2,920.00	\$16,400.00

COMMONWEALTH AVIATION FUND
 FUNDING REQUEST SUMMARY
 VAB DATE: 05/25/2022

Airport: Lake Country Regional Airport
 Region: 6
 Name: Mr. Donald Robertson

Sponsor: Lake Country Airport Commission
 Contact: Mr. Michael Denton , Chairman
 Phone: 434-374-8028

State Funding Summary		
	Requested	Recommended
Entitlement	\$0.00	\$0.00
Air Carrier/Reliever Discretionary	\$10,240.00	\$13,480.00
General Aviation Discretionary	\$3,240.00	\$0.00
TOTALS	\$13,480.00	\$13,480.00

Unmitigated Obstructions

Based Aircraft:	6
Annual Operations:	5,955
Service Role:	RL

Development Program Projects									
Description	Priority	Project Cost	Requested Funding			Recommended Funding			
			Federal	State	Local	Federal	State	Local	
East and West Side Runway Obstruction Survey and Removal	187	\$12,800.00		\$10,240.00	\$2,560.00		\$10,240.00	\$2,560.00	
Security Camera System	147	\$3,600.00		\$3,240.00	\$360.00		\$3,240.00	\$360.00	
TOTALS		\$16,400.00	\$0.00	\$13,480.00	\$2,920.00	\$0.00	\$13,480.00	\$2,920.00	\$0.00

Remarks: East and West Side Runway Obstruction Survey and Removal
 Staff recommends approval.

Security Camera System
 Staff recommends approval.

**AIRPORT CAPITAL IMPROVEMENT PROGRAM
PROJECT NARRATIVE
LAKE COUNTRY REGIONAL AIRPORT (W63)**

The following program narrative addresses the project description and justification for the current year of the Airport Capital Improvement Program.

East and West Side Runway Obstruction Survey and Removal

This project is to survey the trees on the east side of the runway to identify those needing to be removed. Once obstructions are identified, the area will be cleared and grubbed so that the sponsor will be able to maintain it with a mower to keep it clear in the future. The project will also clear the obstructing vegetation on the west side of the runway by clearing and grubbing the area that has grown back.

This request is for 80% state funding for the project.

Security Camera System

This project is to install an exterior security camera system. The system includes 8 cameras, 2 cameras to be mounted on each corner of the terminal building. The recorder and monitor will be in the manager's office in the terminal building. The project also includes labor, wiring, and installation.

This request is for 90% state funding for the project.

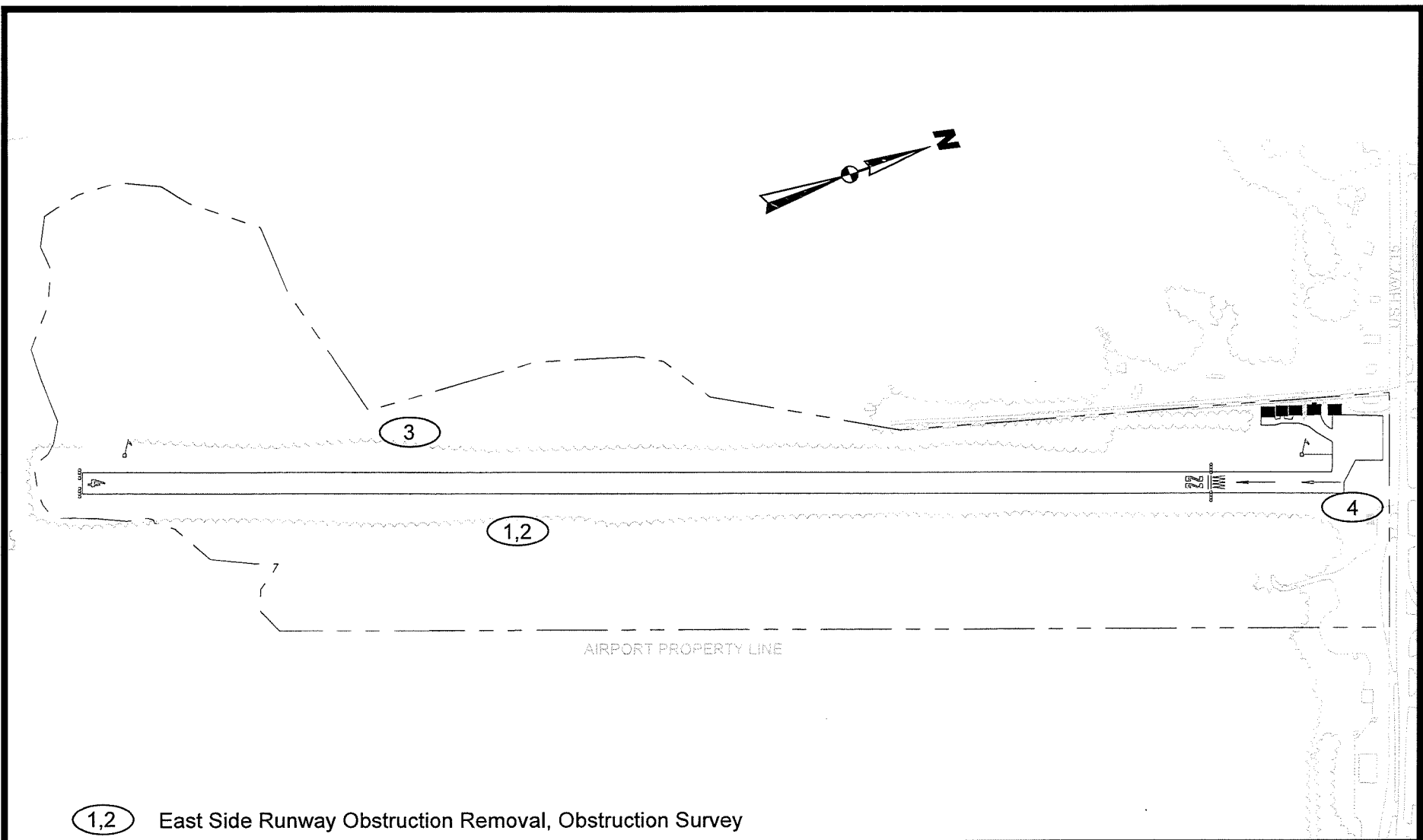
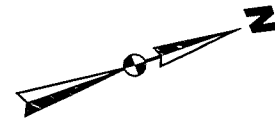

- ①,② East Side Runway Obstruction Removal, Obstruction Survey
- ③ West Side Runway Obstruction Removal
- ④ Security Camera System

ACIP SKETCH
LAKE COUNTRY REGIONAL AIRPORT
TALBERT & BRIGHT ENGINEERING & PLANNING CONSULTANTS 10105 KRAUSE ROAD, SUITE 100 CHESTERFIELD, VIRGINIA 23832 PHONE: 804-768-6878 FAX: 804-768-6871

AIR CARRIER / RELIEVER AIRPORTS - DISCRETIONARY FUNDS
RECOMMENDED PROJECTS

FUNDED

PRIORITY NO.	AIRPORT NAME	DESCRIPTION	FEDERAL AMOUNT	STATE DISCR. AMOUNT	LOCAL AMOUNT	TOTAL PROJECT AMOUNT
190	Hampton Roads Executive Airport	Runway 10-28 Re-Marking (Construction)	\$0.00	\$71,957.00	\$17,990.04	\$89,947.04
189	Hampton Roads Executive Airport	T-Hangar Taxilanes Crack Fill & Sealcoat (Construction)	\$0.00	\$88,564.00	\$22,141.34	\$110,705.34
165	Hampton Roads Executive Airport	West Apron Hangar Site Preparation (Construction) - INCREASE	\$0.00	\$296,457.33	\$74,114.33	\$370,571.66
129	Middle Peninsula Regional Airport	Main Apron & Mid-Field Taxiway Rehabilitation (Design)	\$162,000.00	\$14,400.00	\$3,600.00	\$180,000.00

Region: 7

AIR CARRIER / RELIEVER AIRPORTS - DISCRETIONARY FUNDS
NOT RECOMMENDED PROJECTS

Not Recommended

PRIORITY NO.	AIRPORT NAME	DESCRIPTION	FEDERAL AMOUNT	STATE DISCR. AMOUNT	LOCAL AMOUNT	TOTAL PROJECT AMOUNT
95	Suffolk Executive Airport	T-Hangar G Site Preparation (Design)	\$0.00	\$0.00	\$140,000.00	\$140,000.00
REGION TOTALS:			\$162,000.00	\$471,378.33	\$257,845.71	\$891,224.04

COMMONWEALTH AVIATION FUND
 FUNDING REQUEST SUMMARY
 VAB DATE: 05/25/2022

Airport: Hampton Roads Executive Airport
 Region: 7
 Name: Ms. Vanessa Christie

Sponsor: Virginia Aviation Associates, LLC
 Contact: Mr. Steven Fox , Sponsor
 Phone: 757-373-3151

State Funding Summary		
	Requested	Recommended
Entitlement	\$0.00	\$0.00
Air Carrier/Reliever Discretionary	\$456,978.33	\$456,978.33
General Aviation Discretionary	\$0.00	\$0.00
TOTALS	\$456,978.33	\$456,978.33

Unmitigated Obstructions

Based Aircraft:	165
Annual Operations:	72,708
Service Role:	RL

Development Program Projects									
Description	Priority	Project Cost	Requested Funding			Recommended Funding			
			Federal	State	Local	Federal	State	Local	
Runway 10-28 Re-Marking (Construction)	175	\$89,947.04		\$71,957.00	\$17,990.04		\$71,957.00	\$17,990.04	
T-Hangar Taxilanes Crack Fill & Sealcoat (Construction)	174	\$110,705.34		\$88,564.00	\$22,141.34		\$88,564.00	\$22,141.34	
West Apron Hangar Site Preparation (Construction) - INCREASE	150	\$370,571.66	\$0.00	\$296,457.33	\$74,114.33	\$0.00	\$296,457.33	\$74,114.33	
TOTALS		\$571,224.04	\$0.00	\$456,978.33	\$114,245.71	\$0.00	\$456,978.33	\$114,245.71	

Remarks: Runway 10-28 Re-Marking (Construction)
 Staff recommends approval.

T-Hangar Taxilanes Crack Fill & Sealcoat (Construction)
 Staff recommends approval.

West Apron Hangar Site Preparation (Construction) - INCREASE
 Staff recommends approval.

**AIRPORT CAPITAL IMPROVEMENT PROGRAM
PROJECT NARRATIVE
HAMPTON ROADS EXECUTIVE AIRPORT (PVG)**

Rows 19-30 Taxiway Crack Fill, Seal Coat, and Re-marking at KPVG

Narrative Description of Project and Cost Estimate

Virginia Aviation Associates (Sponsor) is pursuing grant funding for a project to crack fill and seal coat rows 19-30 and the shared taxiway at KPVG. The most recent Pavement Condition Index Survey information for these areas range from 45-59 (poor/fair). The existing subject taxiway surfaces are significantly cracking and creating FOD that is increasingly difficult to manage and the Airport Sponsor has received multiple complaints regarding the condition. Items of work include cleaning all cracks of grass/weeds and debris, filling all cracks ¼” or larger, seal coating, and taxiway re-marking.



RE-MARKING RUNWAY 10-28 at KPVG

Narrative Description of Project and Cost Estimate

Virginia Aviation Associates (Sponsor) is pursuing grant funding for a project to re-paint the markings on runway 10/28 at KPVG. The existing markings are significantly faded and the Airport Sponsor has received multiple complaints regarding the fading condition. Items of work include re-marking Runway 10-28 (5350' x 100', Asphalt). The paint and method of application must be consistent with FAA Specification Item P-620. The Invitation to Bid and the PVG Record Drawing Marking Layout document are also provided for reference.



**AIRPORT CAPITAL IMPROVEMENT PROGRAM
PROJECT NARRATIVE
HAMPTON ROADS EXECUTIVE AIRPORT (PVG)**

The following program narrative addresses the project description and justification for the current year of the Airport Capital Improvement Program.

1 West Apron Hangar Site (Construction) INCREASE

The original construction contract time was 120 calendar days. Due to numerous delays and change orders, the current contract time is now projected to be 413 days. In addition, there have been 11 change orders to date resulting in increases to the construction cost. 80% of the cost increase is related to undercut excavation/poor subgrade soils. In addition to the change order delays, there have been delivery delays related to COVID supply chain issues and having to go back to the City of Chesapeake for approval of design modifications due to field conditions.

This amendment is for increases to the Construction Administration and Construction budgets anticipated for completion of the project.

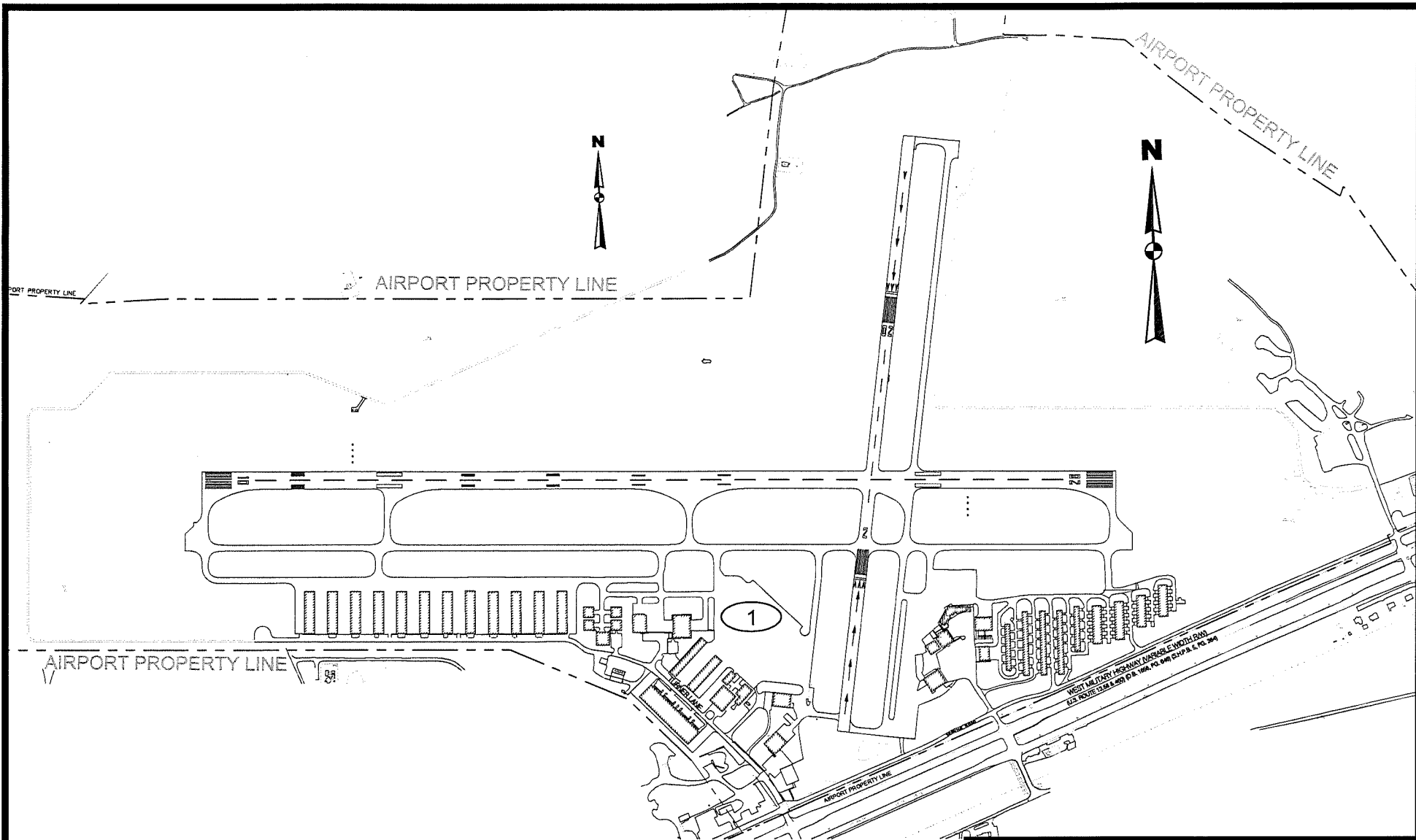

1 WEST APRON HANGAR SITE (CONSTRUCTION) INCREASE

ACIP SKETCH

HAMPTON ROADS EXECUTIVE AIRPORT

TALBERT & BRIGHT
 ENGINEERING & PLANNING CONSULTANTS
 10105 KRAUSE ROAD, SUITE 100
 CHESTERFIELD, VIRGINIA 23832
 PHONE: 804-768-6878 FAX: 804-768-6871

COMMONWEALTH AVIATION FUND
 FUNDING REQUEST SUMMARY
 VAB DATE: 05/25/2022

Airport: Middle Peninsula Regional Airport
 Region: 7
 Name: Ms. Vanessa Christie

Sponsor: Middle Peninsula Regional Airport Authority
 Contact: Ms. Mindy Connors , Manager
 Phone: 804-785-9725

State Funding Summary		
	Requested	Recommended
Entitlement	\$0.00	\$0.00
Air Carrier/Reliever Discretionary	\$14,400.00	\$14,400.00
General Aviation Discretionary	\$0.00	\$0.00
TOTALS	\$14,400.00	\$14,400.00

Unmitigated Obstructions

Based Aircraft:	35
Annual Operations:	15,807
Service Role:	RL

Development Program Projects									
Projects			Requested Funding			Recommended Funding			
Description	Priority	Project Cost	Federal	State	Local	Federal	State	Local	
Main Apron & Mid-Field Taxiway Rehabilitation (Design)	129	\$180,000.00	\$162,000.00	\$14,400.00	\$3,600.00	\$162,000.00	\$14,400.00	\$3,600.00	
TOTALS		\$180,000.00	\$162,000.00	\$14,400.00	\$3,600.00	\$162,000.00	\$14,400.00	\$3,600.00	

Remarks: Main Apron & Mid-Field Taxiway Rehabilitation (Design)
 Staff recommends approval.

**AIRPORT CAPITAL IMPROVEMENT PROGRAM
PROGRAM NARRATIVE
MIDDLE PENINSULA REGIONAL AIRPORT (FYJ)**

The following program narrative addresses the detailed project description and justification for the current year of the Airport Capital Improvement Program.

Main Apron & Mid-Field Taxiway Rehabilitation (Design)

This project is the design and bidding phases of rehabilitating the main apron and mid-field taxiway, both of which were originally constructed in 1997. The PCI numbers indicate now is the time to rehabilitate the pavements before they need more significant repair. The pavement condition in this area is indicated to be fair during the latest Pavement Management Study. This area received environmental approval in the form of a Categorical Exclusion (CatEx).

The project budget includes a Sponsor Administrative Cost allowance for plan review fees, advertisement, shipping and other incidental costs that may be incurred.

This request is for the state 8% match to the upcoming AIP grant.

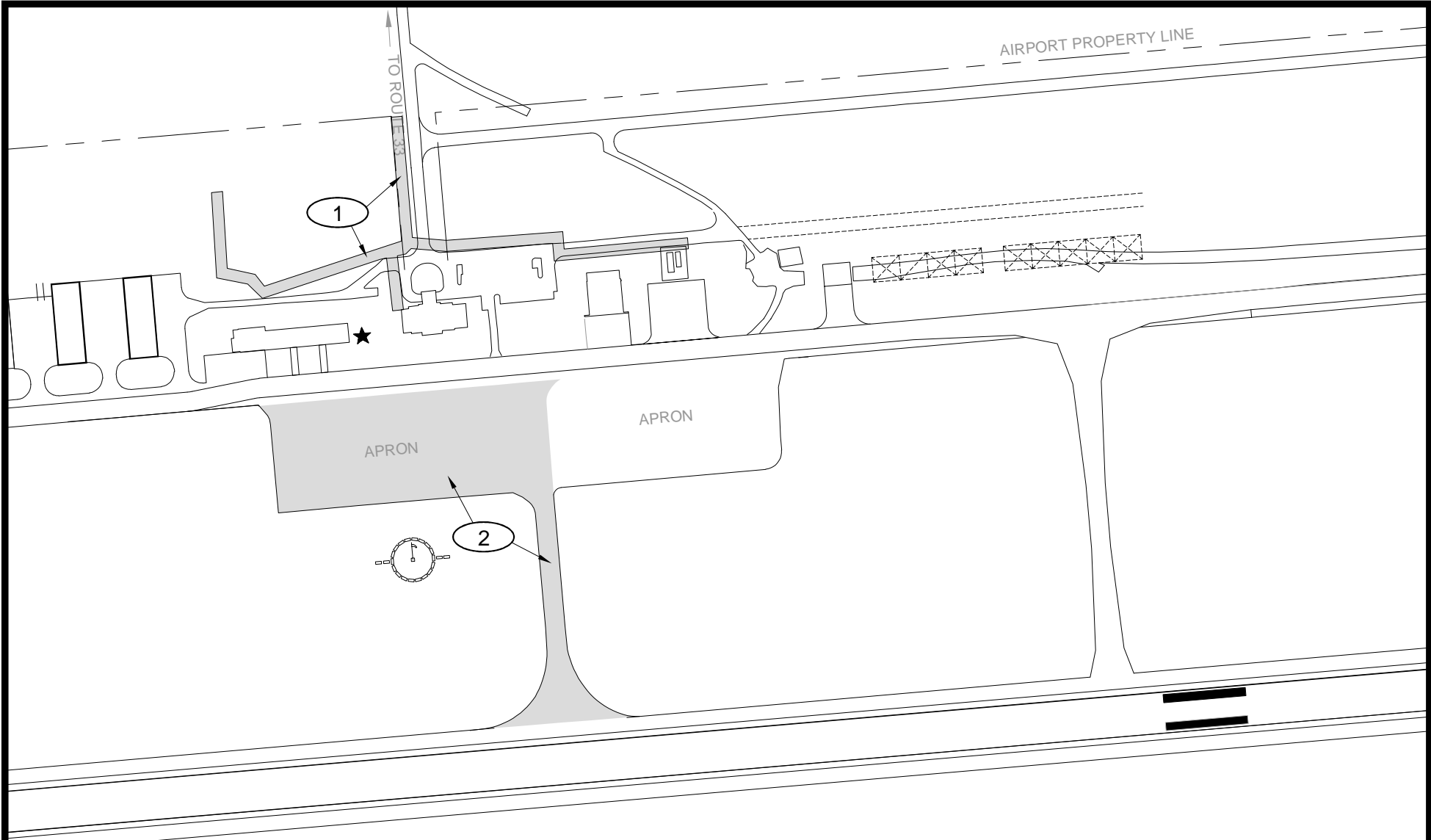

- ① FIBER OPTIC EASEMENT (CATEX)
- ② MAIN APRON & MID-FIELD TAXIWAY REHABILITATION (DESIGN)

ACIP SKETCH
MIDDLE PENINSULA REGIONAL AIRPORT
TALBERT & BRIGHT ENGINEERING & PLANNING CONSULTANTS 10105 KRAUSE ROAD, SUITE 100 CHESTERFIELD, VIRGINIA 23832 PHONE: 804-768-6878 FAX: 804-768-6871

COMMONWEALTH AVIATION FUND
 FUNDING REQUEST SUMMARY
 VAB DATE: 05/25/2022

Airport: Suffolk Executive Airport
 Region: 7
 Name: Ms. Vanessa Christie

Sponsor: City of Suffolk
 Contact: Mr. Tim Daniel , Manager
 Phone: 757-514-4411

State Funding Summary		
	Requested	Recommended
Entitlement	\$0.00	\$0.00
Air Carrier/Reliever Discretionary	\$112,000.00	\$0.00
General Aviation Discretionary	\$0.00	\$0.00
TOTALS	\$112,000.00	\$0.00

Unmitigated Obstructions

Based Aircraft:	69
Annual Operations:	40,502
Service Role:	RL

Development Program Projects									
Description	Priority	Project Cost	Federal	Requested Funding			Recommended Funding		
				State	Local	Federal	State	Local	
T-Hangar G Site Preparation (Design)	95	\$140,000.00		\$112,000.00	\$28,000.00		\$0.00	\$140,000.00	
TOTALS		\$140,000.00	\$0.00	\$112,000.00	\$28,000.00	\$0.00	\$0.00	\$140,000.00	

Remarks: T-Hangar G Site Preparation (Design)
 Staff recommends disapproval.
 The required environmental approvals have not been received.

**AIRPORT CAPITAL IMPROVEMENT PROGRAM
PROGRAM NARRATIVE
SUFFOLK EXECUTIVE AIRPORT (SFQ)**

The following program narrative addresses the detailed project description and justification for the current year of the Airport Capital Improvement Program.

1 – T-Hangar G Site Preparation (Design)

The Suffolk Executive Airport has taken on several development projects in recent years including a full parallel taxiway, improvements to Runway 4-22 pavement, lighting and NAVAIDs. As a result, the sponsor currently has a waiting list for T-Hangars as well as the local financial support to build an additional 10-unit T-Hangar. This project has received environmental approval in the form of a Categorical Exclusion and is consistent with the approved Airport Layout Plan, identified as Hangar No. 15.

The project budget includes a Sponsor Administrative Cost allowance for plan review fees, advertisement, shipping and other incidental costs that may be incurred.

This request is for the 80% state share of the project.

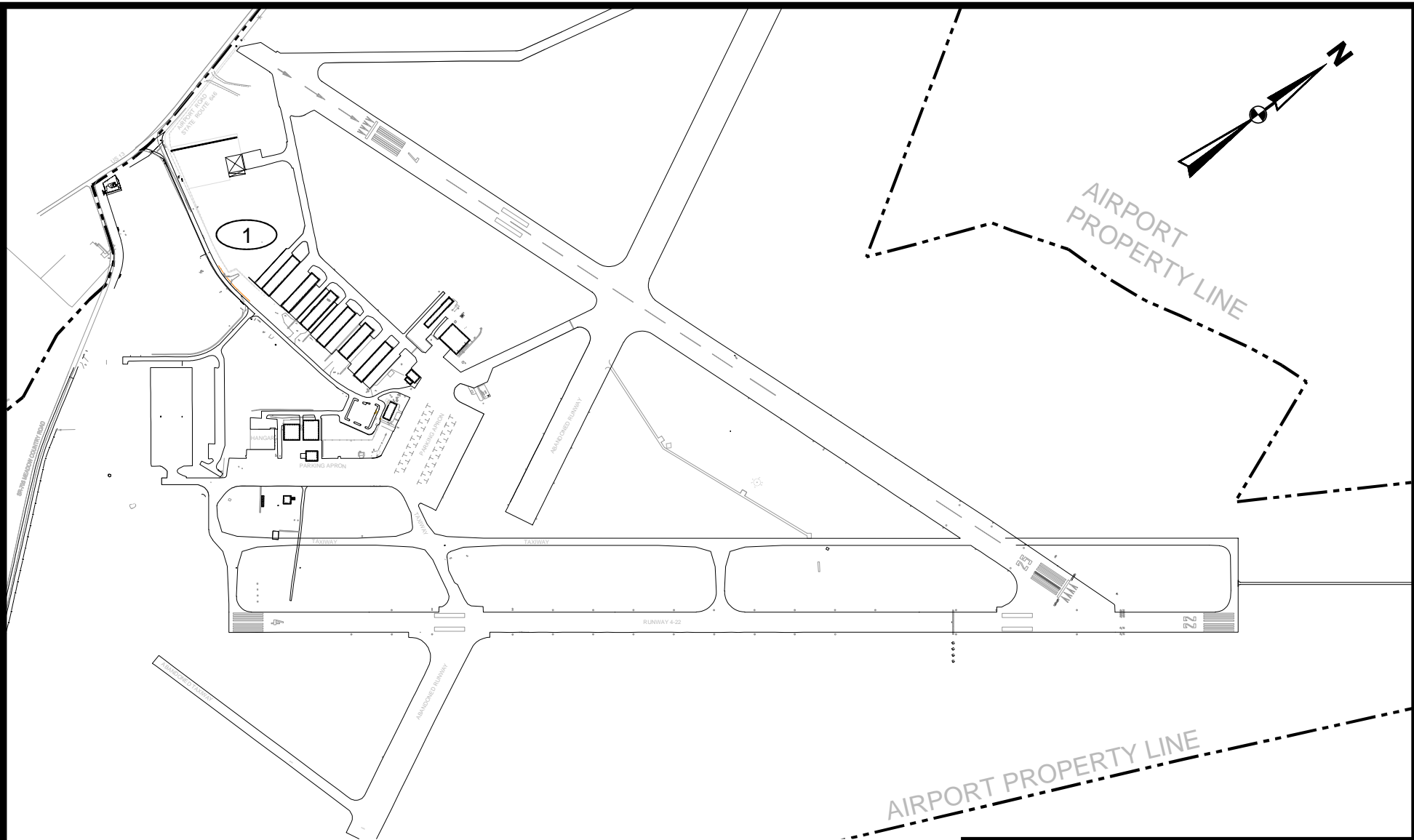

1 T-HANGAR "G" SITE (DESIGN)

ACIP SKETCH

SUFFOLK EXECUTIVE AIRPORT

TALBERT & BRIGHT
 ENGINEERING & PLANNING CONSULTANTS
 10105 KRALUSE ROAD, SUITE 100
 CHESTERFIELD, VIRGINIA 23832
 PHONE: 804-768-6878 FAX: 804-768-6871